

# United States Court of Appeals for the Federal Circuit

95-1066

FESTO CORPORATION,

Plaintiff-Appellee,

v.

SHOKETSU KINZOKU KOGYO KABUSHIKI CO., LTD.,  
a/k/a SMC CORPORATION, and SMC PNEUMATICS, INC.,

Defendants-Appellants.

Charles R. Hoffmann, Hoffmann & Baron, LLP, of Syosset, New York, argued for plaintiff-appellee. With him on the brief were Gerald T. Bodner, Glenn T. Henneberger, and Anthony E. Bennett.

Arthur I. Neustadt, Oblon, Spivak, McClelland, Maier & Neustadt, P.C., of Arlington, Virginia, argued for defendants-appellants. Of counsel on the brief were Charles L. Gholz, and Robert T. Pous. Also of counsel on the brief was James B. Lampert, Hale and Dorr, of Boston, Massachusetts.

J. Michael Jakes, Finnegan, Henderson, Farabow, Garrett & Dunner, L.L.P., of Washington, DC, for amicus curiae American Intellectual Property Law Association. With him on the brief was Louis T. Pirkey, President, of Arlington, Virginia. Of counsel on the brief was Joseph R. Re, Knobbe, Martens, Olson & Bear, L.L.P., of Newport Beach, California.

Frederick A. Lorig, Bright & Lorig, of Los Angeles, California, for amicus curiae Litton Systems, Inc. Of counsel on the brief were John G. Roberts, Jr. and Catherine E. Stetson, Hogan & Hartson L.L.P., of Washington, DC. Also of counsel on the brief were Rory J. Radding, Pennie & Edmonds L.L.P., of New York, New York; and Stanton T. Lawrence, III and Carl P. Bretscher, Pennie & Edmonds L.L.P., of Washington, DC.

William P. Atkins, Pillsbury, Madison & Sutro LLP, of Washington, DC, for amicus curiae, The Patent, Trademark & Copyright Section of The Bar Association of The District of Columbia. With him on the brief were Kendrew H. Colton, Michael A. Conley, Shamita D. Etienne-Cummings and Barbara M. Flaherty.

Roddy M. Bullock, of Cincinnati, Ohio, for amicus curiae The Procter & Gamble Company.

Morgan Chu, Irell & Manella LLP, of Los Angeles, California, for amicus curiae Hewlett-Packard Company. Of counsel on the brief were Perry M. Goldberg and Laura W. Brill.

Christopher A. Hughes, Morgan & Finnegan, L.L.P., of New York, New York, for amici curiae International Business Machines Corporation; Eastman Kodak Company; and Ford Motor Company. Also on the brief was Mark J. Abate. Of counsel on the brief were Frederick T. Boehm, Kevin M. Jordan, Pryor A. Garnett and Mark F. Chadurjian, IBM Corporation, Armonk, New York. Also of counsel on the brief was J. Jeffrey Hawley, Eastman Kodak Company, Rochester, New York; and Roger L. May, Ford Motor Company, Dearborn, Michigan.

Jonathan M. Harris, Conley, Rose & Tayon, P.C., of Houston, Texas, for amicus curiae Houston Intellectual Property Law Association. Of counsel on the brief was James W. Repass, Fulbright & Jaworski, of Houston, Texas.

On remand from the Supreme Court of the United States

# United States Court of Appeals for the Federal Circuit

95-1066

FESTO CORPORATION,

Plaintiff-Appellee,

v.

SHOKETSU KINZOKU KOGYO KABUSHIKI CO., LTD., a/k/a SMC CORPORATION,  
and SMC PNEUMATICS, INC.,

Defendants-Appellants.

---

DECIDED: November 29, 2000

---

Before MAYER, Chief Judge, NEWMAN, MICHEL, PLAGER, LOURIE, CLEVINGER, RADER, SCHALL, BRYSON, GAJARSA, LINN, and DYK, Circuit Judges.

Opinion for the court filed by Circuit Judge SCHALL, in which Chief Judge MAYER and Circuit Judges PLAGER, LOURIE, CLEVINGER, BRYSON, GAJARSA, and DYK join; in which Circuit Judges MICHEL, RADER, and LINN join with respect to PARTS III-A, III-B, and III-D; and in which Circuit Judge MICHEL joins with respect to PART III-E.

Concurring opinion filed by Circuit Judge PLAGER.

Concurring opinion filed by Circuit Judge LOURIE.

Opinion concurring-in-part and dissenting-in-part with respect to PART III-C filed by Circuit Judge MICHEL, in which Circuit Judge RADER joins.

Opinion concurring-in-part and dissenting-in-part with respect to PART III-C filed by Circuit Judge RADER, in which Circuit Judges MICHEL and LINN join.

Opinion concurring-in-part and dissenting-in-part with respect to PART III-C filed by Circuit Judge LINN, in which Circuit Judge RADER joins.

Opinion concurring-in-part and dissenting-in-part with respect to PARTS III-A, III-B, III-C, and IV filed by Circuit Judge NEWMAN.

SCHALL, Circuit Judge.

This is an appeal from the judgment of the United States District Court for the District of Massachusetts that Shoketsu Kinzoku Kogyo Kabushiki Co., Ltd. (also known as SMC Corporation) and SMC Pneumatics, Inc. (collectively, “SMC”) infringed U.S. Patent No. 4,354,125 (the “Stoll patent”) and U.S. Patent No. B1 3,779,401 (the “Carroll patent”), both owned by Festo Corporation (“Festo”), under the doctrine of equivalents. We took the case en banc to resolve certain issues relating to the doctrine of equivalents that remained in the wake of the Supreme Court’s decision in Warner-Jenkinson Co. v. Hilton Davis Chemical Co., 520 U.S. 17 (1997). Specifically, we asked the parties to brief the following five questions for rehearing en banc:

1. For the purposes of determining whether an amendment to a claim creates prosecution history estoppel, is “a substantial reason related to patentability,” Warner-Jenkinson Co. v. Hilton Davis Chem. Co., 520 U.S. 17, 33, 117 S. Ct. 1040, 137 L. Ed. 2d 146 (1997), limited to those amendments made to overcome prior art under § 102 and § 103, or does “patentability” mean any reason affecting the issuance of a patent?

2. Under Warner-Jenkinson, should a “voluntary” claim amendment—one not required by the examiner or made in response to a rejection by an examiner for a stated reason—create prosecution history estoppel?

3. If a claim amendment creates prosecution history estoppel, under Warner-Jenkinson what range of equivalents, if any, is available under the doctrine of equivalents for the claim element so amended?

4. When “no explanation [for a claim amendment] is established,” Warner-Jenkinson, 520 U.S. at 33, 117 S. Ct. 1040, thus invoking the presumption of prosecution history estoppel under Warner-Jenkinson, what range of equivalents, if any, is available under the doctrine of equivalents for the claim element so amended?

5. Would a judgment of infringement in this case violate Warner-Jenkinson's requirement that the application of the doctrine of equivalents “is not allowed such broad play as to eliminate [an] element in its entirety,” 520 U.S. at 29, 117 S. Ct. 1040. In other words, would such

a judgment of infringement, post Warner-Jenkinson, violate the “all elements” rule?

Festo Corp. v. Shoketsu Kinzoku Kogyo Kabushiki Co., 187 F.3d 1381, 1381-82, 51 USPQ2d 1959, 1959-60 (Fed. Cir. 1999) (“Festo V”).

We begin with a brief synopsis of our answers to the en banc questions and a summary of how those answers affect the disposition of this appeal. In response to En Banc Question 1, we hold that “a substantial reason related to patentability” is not limited to overcoming prior art, but includes other reasons related to the statutory requirements for a patent. Therefore, an amendment that narrows the scope of a claim for any reason related to the statutory requirements for a patent will give rise to prosecution history estoppel with respect to the amended claim element.<sup>1</sup> In response to En Banc Question 2, we hold that “voluntary” claim amendments are treated the same as other claim amendments; therefore, any voluntary amendment that narrows the scope of a claim for a reason related to the statutory requirements for a patent will give rise to prosecution history estoppel with respect to the amended claim element. In response to En Banc Question 3, we hold that when a claim amendment creates prosecution history estoppel, no range of equivalents is available for the amended claim element. In response to En Banc Question 4, we hold that “unexplained” amendments

---

<sup>1</sup> In our prior cases, we have used both the term “element” and the term “limitation” to refer to words in a claim. See, e.g., Lemelson v. United States, 752 F.2d 1538, 1551, 224 USPQ 526, 533 (Fed. Cir. 1985) (using the term “element”); Sextant Avionique, S.A. v. Analog Devices, Inc., 172 F.3d 817, 826-27, 49 USPQ2d 1865, 1870-71 (Fed. Cir. 1999) (using the term “limitation”). It is preferable to use the term “limitation” when referring to claim language and the term “element” when referring to the accused device. See Dawn Equip. Co. v. Kentucky Farms, Inc., 140 F.3d 1009, 1014 n.1, 46 USPQ2d 1109, 1112 n.1 (Fed. Cir. 1998). However, because the en banc questions use the term “element,” we use that term in this opinion.

are not entitled to any range of equivalents. We do not reach En Banc Question 5, for reasons which will become clear in our discussion of the specific case before us.

In view of our answers to the en banc questions, we reverse the judgment that claim 1 of the Stoll patent and claims 5, 6, and 9 of the Carroll patent were infringed under the doctrine of equivalents. The claim elements that were found to be infringed by equivalents were added during prosecution of the Stoll patent and during reexamination of the Carroll patent. The amendments that added those elements narrowed the scope of the claims. Festo has not established explanations unrelated to patentability for these amendments; accordingly, no range of equivalents is available for the amended claim elements. Because the parties agree that SMC does not produce a device that literally satisfies those claim elements, the judgment of infringement must be reversed.

Section I of this opinion provides a brief overview of the doctrine of equivalents and prosecution history estoppel. Section II discusses the Supreme Court's decision in Warner-Jenkinson. Section III sets forth our answers to the en banc questions. In Section IV, we decide the appeal before us by applying our answers to the en banc questions to the facts of the case.

## DISCUSSION

### I. The Doctrine of Equivalents and Prosecution History Estoppel

The doctrine of equivalents prevents an accused infringer from avoiding liability for infringement by changing only minor or insubstantial details of a claimed invention while retaining the invention's essential identity. Graver Tank & Mfg. Co. v. Linde Air Prods. Co., 339 U.S. 605, 608 (1950). The doctrine of equivalents is utilized “[t]o

temper unsparing logic and prevent an infringer from stealing the benefit of the invention.” Id. (quoting Royal Typewriter Co. v. Remington Rand, Inc., 168 F.2d 691, 692, 77 USPQ 517, 518 (2d Cir. 1948) (Hand, J.)). In pursuing these goals, the doctrine attempts to strike a balance between ensuring that the patentee enjoys the full benefit of his patent and ensuring that the claims give “fair notice” of the patent’s scope. London v. Carson Pirie Scott & Co., 946 F.2d 1534, 1538, 20 USPQ2d 1456, 1458-59 (Fed. Cir. 1991). This balance can be easily upset, however, because “the doctrine of equivalents, when applied broadly, conflicts with the definitional and public-notice functions of the statutory claiming requirement.” Warner-Jenkinson, 520 U.S. at 29.

Prosecution history estoppel is one tool that prevents the doctrine of equivalents from vitiating the notice function of claims. Charles Greiner & Co. v. Mari-Med Mfg., Inc., 962 F.2d 1031, 1036, 22 USPQ2d 1526, 1529-30 (Fed. Cir. 1992). Actions by the patentee, including claim amendments and arguments made before the Patent Office, may give rise to prosecution history estoppel. Pharmacia & Upjohn Co. v. Mylan Pharms., Inc., 170 F.3d 1373, 1376-77, 50 USPQ2d 1033, 1036 (Fed. Cir. 1999). “Prosecution history estoppel precludes a patentee from obtaining under the doctrine of equivalents coverage of subject matter that has been relinquished during the prosecution of its patent application.” Id. at 1376, 50 USPQ2d at 1036. Therefore, “[t]he doctrine of equivalents is subservient to . . . [prosecution history] estoppel.” Autogiro Co. v. United States, 384 F.2d 391, 400-01, 155 USPQ 697, 705 (Ct. Cl. 1967). The logic of prosecution history estoppel is that the patentee, during prosecution, has created a record that fairly notifies the public that the patentee has surrendered the right to claim particular matter as within the reach of the patent.

## II. Warner-Jenkinson

In this en banc rehearing, we focus our attention on the effect of Warner-Jenkinson on our case law relating to the doctrine of equivalents and prosecution history estoppel. Festo V, 187 F.3d at 1381-82, 51 USPQ2d at 1959-60; see also Shoketsu Kinzoku Kogyo Kabushiki Co. v. Festo Corp., 520 U.S. 1111 (1997) (“Festo III”) (remanding the case for further consideration in light of the Warner-Jenkinson decision).

The patent before the Court in Warner-Jenkinson disclosed an improved process for purifying dyes which used a method called “ultrafiltration.” Warner-Jenkinson, 520 U.S. at 21. During prosecution, the patentee amended the claims to recite that the process is carried out “at a pH from approximately 6.0 to 9.0.” Id. at 22. The accused process was carried out at a pH of 5.0. Id. at 23. In light of these facts, the Supreme Court embarked on an “endeavor to clarify the proper scope of the doctrine” of equivalents. Id. at 21.

The Court dismissed the arguments of Warner-Jenkinson (the alleged infringer) that the doctrine of equivalents, as established in Graver Tank, did not survive the 1952 revision of the Patent Act. Id. at 25-27. The Court nevertheless noted its concern that “the doctrine of equivalents, as it has come to be applied since Graver Tank, has taken on a life of its own.” Id. at 28-29. The Court agreed with Warner-Jenkinson “that Graver Tank did not dispose of prosecution history estoppel as a legal limitation on the doctrine of equivalents.” Id. at 30. However, the Court rejected Warner-Jenkinson’s argument “that the reason for an amendment during patent prosecution is irrelevant to any subsequent estoppel.” Id. The Court noted that “[i]n each of our cases cited by

petitioner and by the dissent below, prosecution history estoppel was tied to amendments made to avoid the prior art, or otherwise to address a specific concern—such as obviousness—that arguably would have rendered the claimed subject matter unpatentable.” Id. at 30-31. The Court therefore saw “no substantial cause for requiring a more rigid rule invoking an estoppel regardless of the reasons for a change.” Id. at 32 (footnote omitted).

Turning to the facts at hand, the Court noted that, although the parties did not dispute that the upper pH limit of 9.0 was added to avoid the prior art, “the reason for adding the lower limit of 6.0 is unclear.” Id. Presented “with the problem . . . where the record seems not to reveal the reason for including the lower pH limit of 6.0,” the Court “place[d] the burden on the patent holder to establish the reason for an amendment required during patent prosecution.” Id. at 33. The Court stated that courts will have to “decide whether the [proffered] reason is sufficient to overcome prosecution history estoppel as a bar to application of the doctrine of equivalents to the element added by that amendment.” Id. The Court also stated that “[w]here no explanation is established, . . . the court should presume that the patent applicant had a substantial reason related to patentability for including the limiting element added by the amendment.” Id. Therefore, “prosecution history estoppel would bar the application of the doctrine of equivalents as to that element.” Id. Because Hilton Davis had “not proffered in . . . [the Supreme] Court a reason for the addition of the lower pH limit,” the Court remanded the case for this court to consider whether Hilton Davis had offered reasons for the amendment that added the lower pH limit and to determine whether Hilton Davis should be given the opportunity to establish such reasons. Id. at 34.

The Court rejected the other restrictions on the doctrine of equivalents proposed by Warner-Jenkinson. Id. at 35-40. Specifically, the Court refused to “require judicial exploration of the equities of a case before allowing application of the doctrine of equivalents,” id. at 34, refused to require “proof of intent” on the part of the alleged infringer before the doctrine of equivalents could be applied, id. at 35-36, and refused to adopt “independent experimentation” as “an equitable defense to the doctrine of equivalents,” id. at 36. The Court also refused to limit the doctrine of equivalents “to equivalents that are disclosed within the patent itself,” reasoning that the “proper time for evaluating equivalency . . . is at the time of infringement, not at the time the patent was issued.” Id. at 37.

In closing, the Court stated that it chose to “adhere to the doctrine of equivalents,” which “should be applied as an objective inquiry on an element-by-element basis.” Id. at 40. The Court noted that “[p]rosecution history estoppel continues to be available as a defense to infringement.” Id. However, “if the patent holder demonstrates that an amendment required during prosecution had a purpose unrelated to patentability, a court must consider that purpose in order to decide whether an estoppel is precluded.” Id. at 40-41. If “the patent holder is unable to establish such a purpose, a court should presume that the purpose behind the required amendment is such that prosecution history estoppel would apply.” Id. at 41.

### III. Answers to the En Banc Questions

#### A. Question 1

For the purposes of determining whether an amendment to a claim creates prosecution history estoppel, is “a substantial reason related to patentability,” Warner-Jenkinson Co. v. Hilton Davis Chem. Co., 520 U.S. 17, 33, 117 S. Ct. 1040, 137 L. Ed. 2d 146 (1997), limited to those

amendments made to overcome prior art under § 102 and § 103, or does “patentability” mean any reason affecting the issuance of a patent?

We answer Question 1 as follows: For the purposes of determining whether an amendment gives rise to prosecution history estoppel, a “substantial reason related to patentability” is not limited to overcoming or avoiding prior art, but instead includes any reason which relates to the statutory requirements for a patent. Therefore, a narrowing amendment made for any reason related to the statutory requirements for a patent will give rise to prosecution history estoppel with respect to the amended claim element.

It is true that in Warner-Jenkinson the Supreme Court focused on claim amendments made to overcome or avoid prior art. Warner-Jenkinson, 520 U.S. at 30-34. However, there are a number of statutory requirements that must be satisfied before a valid patent can issue and that thus relate to patentability. In addition to satisfying the novelty and non-obviousness requirements of 35 U.S.C. §§ 102 and 103, 35 U.S.C.A. §§ 102, 103 (West 1994 & Supp. 2000), the claims must be directed to patentable subject matter and the claimed invention must be useful, as set forth in 35 U.S.C. § 101 (1994). Additionally, the first paragraph of 35 U.S.C. § 112 requires that the patent specification describe, enable, and set forth the best mode of carrying out the invention, 35 U.S.C. § 112, ¶ 1 (1994), while the second paragraph of section 112 requires that the claims set forth the subject matter that the applicant regards as his invention and that the claims particularly point out and distinctly define the invention, 35 U.S.C. § 112, ¶ 2 (1994). The Patent Office will reject a patent application that fails to satisfy any one of these statutory requirements. See Man. Pat. Exam. P. 2100-1 to -173 (7th ed. rev. 1 1998). And any one of these requirements may be a ground for invalidating an issued patent. E.g., 35 U.S.C. § 282 (1994); Atlas Powder Co. v. Ireco,

Inc., 190 F.3d 1342, 51 USPQ2d 1943 (Fed. Cir. 1999) (holding a patent invalid because the claims were anticipated under 35 U.S.C. § 102); Mitsubishi Elec. Corp. v. Ampex Corp., 190 F.3d 1300, 51 USPQ2d 1910 (Fed. Cir. 1999) (holding a patent invalid because the claims were obvious under 35 U.S.C. § 103); State Street Bank & Trust Co. v. Signature Fin. Group, Inc., 149 F.3d 1368, 47 USPQ2d 1596 (Fed. Cir. 1998) (discussing the patentable subject matter requirement of 35 U.S.C. § 101); Process Control Corp. v. HydReclaim Corp., 190 F.3d 1350, 52 USPQ2d 1029 (Fed. Cir. 1999) (holding a patent invalid because the claims were inoperative and therefore failed to satisfy the utility requirement of 35 U.S.C. § 101); Johnson Worldwide Assoc., Inc. v. Zebco Corp., 175 F.3d 985, 50 USPQ2d 1607 (Fed. Cir. 1999) (considering whether a patent claim was invalid under the written description requirement of § 112, ¶ 1); Gentry Gallery, Inc. v. Berklene Corp., 134 F.3d 1473, 45 USPQ2d 1498 (Fed. Cir. 1998) (holding claims of a patent invalid for failing to comply with the written description requirement of § 112, ¶ 1); Enzo Biochem, Inc. v. Calgene, Inc., 188 F.3d 1362, 52 USPQ2d 1129 (Fed. Cir. 1999) (holding a patent invalid because the claims were not enabled, as required by 35 U.S.C. § 112, ¶ 1); United States Gypsum Co. v. Nat'l Gypsum Co., 74 F.3d 1209, 37 USPQ2d 1388 (Fed. Cir. 1996) (holding a patent invalid for failing to satisfy the best mode requirement of 35 U.S.C. § 112, ¶ 1); Morton Int'l, Inc. v. Cardinal Chem. Co., 5 F.3d 1464, 28 USPQ2d 1190 (Fed. Cir. 1993) (holding a patent invalid because the claims failed to satisfy the definiteness requirement of 35 U.S.C. § 112, ¶ 2). An amendment related to any of these statutory requirements is an amendment made for “a substantial reason related to patentability.”

The law has been clear that amendments made to avoid prior art give rise to prosecution history estoppel. E.g., Warner-Jenkinson, 520 U.S. at 30-31 (discussing Exhibit Supply Co. v. Ace Patents Corp., 315 U.S. 126 (1942), and Keystone Driller Co. v. Northwest Eng'g Corp., 294 U.S. 42 (1935)). In view of the functions of prosecution history estoppel—preserving the notice function of the claims and preventing patent holders from recapturing under the doctrine of equivalents subject matter that was surrendered before the Patent Office—we see no reason why prosecution history estoppel should not also arise from amendments made for other reasons related to patentability, as described above. Indeed, the functions of prosecution history estoppel cannot be fully satisfied if substantial reasons related to patentability are limited to a narrow subset of patentability issues. Rather, substantial reasons related to patentability include 35 U.S.C. §§ 101 and 112 issues, as well as 35 U.S.C. §§ 102 and 103 issues.

While we do not believe that the Supreme Court itself answered this question in Warner-Jenkinson, we do believe that our answer is not inconsistent with Warner-Jenkinson. Warner-Jenkinson describes prior cases as applying prosecution history estoppel “typically because what [was previously claimed] . . . was encompassed within the prior art,” 520 U.S. at 31 (emphasis added), but no language in Warner-Jenkinson limits prosecution history estoppel to amendments made to avoid prior art. See also Crawford v. Heysinger, 123 U.S. 589, 606 (1887) (finding prosecution history estoppel to arise from amendments made in response to operability rejections). Moreover, our approach is consistent with Warner-Jenkinson's requirement that an amendment “does not necessarily preclude infringement by equivalents of that element.” Id. at 33. Thus,

if a patent holder can show from the prosecution history that a claim amendment was not motivated by patentability concerns, the amendment will not give rise to prosecution history estoppel.

B. Question 2

Under Warner-Jenkinson, should a “voluntary” claim amendment—one not required by the examiner or made in response to a rejection by an examiner for a stated reason—create prosecution history estoppel?

We answer Question 2 as follows: Voluntary claim amendments are treated the same as other amendments. Therefore, a voluntary amendment that narrows the scope of a claim for a reason related to the statutory requirements for a patent will give rise to prosecution history estoppel as to the amended claim element.

Both voluntary amendments and amendments required by the Patent Office signal to the public that subject matter has been surrendered. There is no reason why prosecution history estoppel should arise if the Patent Office rejects a claim because it believes the claim to be unpatentable, but not arise if the applicant amends a claim because he believes the claim to be unpatentable.

Our answer to this question is consistent with the doctrine of argument-based estoppel. Arguments made voluntarily during prosecution may give rise to prosecution history estoppel if they evidence a surrender of subject matter. E.g., KCJ Corp. v. Kinetic Concepts, Inc., 223 F.3d 1351, 1359-60, 55 USPQ2d 1835, 1841-42 (Fed. Cir. 2000) (concluding that “KCJ’s statements [during prosecution] reflect a clear and unmistakable surrender” of subject matter that cannot be reclaimed through the doctrine of equivalents); Bayer AG v. Elan Pharm. Research Corp., 212 F.3d 1241, 1252-53, 54 USPQ2d 1711, 1719 (Fed. Cir. 2000) (finding that “through [Bayer’s]

statements to the PTO and the declarations it filed, Bayer made statements of clear and unmistakable surrender of subject matter” which it could not recapture through the doctrine of equivalents); Pharmacia & Upjohn, 170 F.3d at 1377, 50 USPQ2d at 1036 (“A number of activities during prosecution may give rise to prosecution history estoppel, . . . including arguments made to obtain allowance of the claims at issue.” (citation omitted)); Southwall Techs., Inc. v. Cardinal IG Co., 54 F.3d 1570, 1583, 34 USPQ2d 1673, 1682 (Fed. Cir. 1995) (“Clear assertions made during prosecution in support of patentability, whether or not actually required to secure allowance of the claim, may . . . create an estoppel.”); Texas Instruments Inc. v. United States Int’l Trade Comm’n, 988 F.2d 1165, 1174, 26 USPQ2d 1018, 1025 (Fed. Cir. 1993) (holding that arguments made during prosecution that emphasized one feature of the invention estopped the patent holder from asserting that a device lacking that feature infringed the patent under the doctrine of equivalents). There is no reason why an amendment-based surrender of subject matter should be given less force than an argument-based surrender of subject matter.

We also believe that our answer to this question is consistent with Warner-Jenkinson. Although the Supreme Court spoke of “required” amendments, the claim amendment at issue in Warner-Jenkinson, the addition of the lower pH limit of 6, was not “required” by the prior art rejection. The original claim recited an ultrafiltration process. Warner-Jenkinson, 520 U.S. at 21. The asserted prior art reference taught an ultrafiltration process conducted at a pH of above 9. Id. at 22. The amended claim recited an ultrafiltration process conducted “at a pH from approximately 6.0 to 9.0.” Id. The parties did not dispute that the upper pH limit of 9.0 was added to distinguish the

prior art. Id. at 32. The Court, however, was unable to discern the reason for the addition of the lower pH limit of 6. Id. at 32-33. Accordingly, the amendment at issue in Warner-Jenkinson appears to have been voluntary with respect to the lower pH limit. Nevertheless, the Court held that the amendment adding the lower pH limit could give rise to prosecution history estoppel. Id. at 34.

C. Question 3

If a claim amendment creates prosecution history estoppel, under Warner-Jenkinson what range of equivalents, if any, is available under the doctrine of equivalents for the claim element so amended?

We answer Question 3 as follows: When a claim amendment creates prosecution history estoppel with regard to a claim element, there is no range of equivalents available for the amended claim element. Application of the doctrine of equivalents to the claim element is completely barred (a “complete bar”).

We think it is fair to say that the question of the scope of equivalents available when prosecution history estoppel applies to a claim element has not been directly addressed or answered by the Supreme Court, at least in circumstances where the claim was amended for a known patentability reason. In Warner-Jenkinson, the Court focused its attention more on the circumstances under which prosecution history estoppel arises than on the range of equivalents that might generally be available despite the existence of prosecution history estoppel. Warner-Jenkinson, 520 U.S. at 30-34. The Court did not discuss the upper pH limit of 9.0, other than to note that the upper limit, which narrowed the claim, was selected to overcome prior art. Id. at 32. The range of equivalents, if any, that could be asserted for the upper pH limit was not discussed by the Court. The only statements in Warner Jenkinson as to the range of

equivalents that is available when prosecution history estoppel applies are found in the Court's discussion of unexplained amendments. Id. at 33-34. For those amendments, the Court held that "prosecution history estoppel would bar the application of the doctrine [of] equivalents as to that element." Id. at 33.

1. In cases before Warner-Jenkinson, the Supreme Court applied prosecution history estoppel to preclude a finding of infringement under the doctrine of equivalents, but the Court did not analyze the actual scope of equivalents that might be available when prosecution history estoppel applied, i.e., the extent of the subject matter surrendered by amendment. In Weber Electric Co. v. E.H. Freeman Electric Co., 256 U.S. 668 (1921), the patentee had amended his claim to an electric lamp socket to overcome prior art that taught a socket and electric bulb that were unlocked and locked together simply by rotation. The amended claim recited, instead, a bulb and socket combination that unlocked and locked by manual compression. Id. at 677. In light of this amendment, the Court did not allow the patentee, who had "narrowed his claim . . . to obtain a patent," to "resort to the doctrine of equivalents [and] give to the claim the larger scope which it might have had without the amendment." Id. Under the facts of the case, the alleged infringer practiced the exact subject matter described in the prior art, a combination that locked the bulb by rotational movement. Id. at 678. Thus, the Court did not need to discuss the precise contours of the subject matter surrendered by the claim amendment. A similar situation was presented in Smith v. Magic City Kennel Club, 282 U.S. 784 (1931). The invention at issue in that case involved an artificial dog race track lure. Id. at 786-87. The patentee overcame prior art that disclosed a straight arm for holding the lure by amending his claims to recite a

hinged arm. Id. at 788-89. The accused infringer's device used a rigid arm. Id. The Court did not allow the patentee to resort to the doctrine of equivalents to regain the specific subject matter the patentee had surrendered "in order to escape rejection." Id. at 790.

In Magic City Kennel Club, as in Weber, the accused device read on the prior art, which in and of itself mandates a finding of noninfringement, see Wilson Sporting Goods Co. v. David Geoffrey & Assocs., 904 F.2d 677, 683-85, 14 USPQ2d 1942, 1947-49 (Fed. Cir. 1990) (noting that the doctrine of equivalents cannot be applied to encompass the prior art). In Exhibit Supply Co. v. Ace Patents Corp., 315 U.S. 126 (1942), the patentee amended the claim at issue to overcome general prior art cited by the examiner. He did so by changing the claim to recite a conductor device that was "embedded in" a game table (pinball machine) instead of one that was "carried by" the table. Exhibit Supply, 315 U.S. at 136-37. The Court held that the patentee could not thereafter, through the doctrine of equivalents, obtain coverage of accused devices in which the "conductor means" was carried by the game table instead of imbedded in it. Id. It is unclear from the Court's opinion whether the accused device was in the prior art cited by the examiner in his rejection. Id. at 133 (quoting the examiner's assertion that it was plainly "old in the art to make an electrical contact by flexing a coil spring as shown by the art already cited in the case"). The Court stated, however:

Had Claim 7 been allowed in its original form, it would have read upon all the accused devices, since in all the conductor means complementary to the coil spring are "carried by the table." By striking that phrase from the claim and substituting for it "embedded in the table," the applicant restricted his claim to those combinations in which the conductor means, though carried on the table, is also embedded in it. By the amendment, he recognized and emphasized the difference between the two phrases and proclaimed his abandonment of all that is embraced in that difference.

Id. at 136. The Court never addressed the exact range of equivalents that might still be available under the amended claim, and the “difference between” the original claim and the amended claim, the difference said by the Court to have been abandoned by the patentee, was never explicitly defined.

In his dissenting opinion, Judge Michel relies upon Goodyear Dental Vulcanite Co. v. Davis, 102 U.S. 222 (1880), and Hurlbut v. Schillinger, 130 U.S. 456 (1889), for the proposition that a patentee is entitled to a range of equivalents despite the fact that the scope of a claim has been limited by amendment. We do not believe, however, that either of these cases addresses the issue presented in En Banc Question 3: the range of equivalents, if any, that is available under the doctrine of equivalents for a claim element that has been amended by an amendment that creates prosecution history estoppel.

As issued, the claim in Goodyear described "rubber or some other elastic material" for a dental plate. Goodyear, 102 U.S. at 224-25. During reissue the claim was amended to describe a dental plate of hard or “vulcanized” rubber. Id. at 228. Looking to the reissue amendment, the Court concluded that the patentee “regarded the patent to be for a manufacture made exclusively of vulcanites by the detailed process.” Id. The Court determined that there could be no infringement where the defendant’s product used celluloid. Id. at 229-30. The Court did not discuss prosecution history estoppel, but simply decided that under the language of the reissued patent celluloid was not equivalent to “hard rubber or vulcanite or its equivalent.”

Hurlbut involved a patent which had been reissued and in which a disclaimer had been filed. Hurlbut, 130 U.S. at 462-63. The reissue added a second claim, but did not amend any claim language. Id. Claim 1 recited “[a] concrete pavement laid in detached blocks or sections, substantially in the manner shown and described.” Id. at 463. Claim 2 recited an “arrangement of tar paper, or its equivalent, between adjoining blocks of concrete, substantially as and for the purpose set forth.” Id. The patentee disclaimed “the forming of blocks from plastic material without interposing anything between their joints while in the process of formation.” Id. In the face of this disclaimer, the Court construed the claims to require that the division of the concrete paving blocks be “effected by either a permanent or temporary imposition of something between the blocks.” Id. at 465. The Court held that both claims were infringed by a process in which a trowel was used to cut a concrete layer into blocks. Id. at 469. In referring to equivalents the Court was referring to the language of the claims (“substantially” in claim 1 and “or its equivalents” in claim 2). Thus, the Court did not discuss the issue of the scope of equivalents that remained under the doctrine of equivalents after the disclaimer.

Neither do we believe that in any of the other cases noted by Judge Michel did the Court determine that a claim element that was amended by an amendment that gave rise to prosecution history estoppel was entitled to a range of equivalents. See Cal. Artificial Stone-Paving Co. v. Schalicke, 119 U.S. 401, 407 (1886) (stating that there was no infringement “under any construction which it is possible to give the claims”); Fay v. Cordesman, 109 U.S. 408, 420-21 (1883) (finding that the accused device lacked material elements of the claimed inventions without discussing

prosecution history estoppel or the doctrine of equivalents); Shepard v. Carrigan, 116 U.S. 593, 597-98 (1886) (reversing a judgment of infringement and noting that the prior art and the accused device depicted a skirt protector without a “fluted or plaited band or border,” while the patent described a skirt protector with such a border); Sutter v. Robinson, 119 U.S. 530, 541-42 (1886) (reversing a judgment of infringement and stating that the prior art and the accused device involved a metal box for storing tobacco leaves, while the patent described a wooden box); Phoenix Caster Co. v. Spiegel, 133 U.S. 360, 364, 368-69 (1890) (holding that there was no infringement because the accused device did not have, as the claim recited, a “rocker-formed collar-bearing, or its mechanical equivalent”); Royer v. Coure, 146 U.S. 524, 531-32 (1892) (determining that the defendants could not infringe “under the proper construction of the claim of the patent” because the process they practiced lacked an element of the claimed process); Hubbell v. United States, 179 U.S. 77, 80, 85 (1900) (using prosecution history to construe the claim and finding no infringement, without discussing prosecution history estoppel).

In short, the range of equivalents available to an amended claim element simply was not before the Supreme Court in the cases Judge Michel cites, and the Supreme Court did not discuss the issue presented in En Banc Question 3. Although a court must follow “explicit and carefully considered” language of the Supreme Court, see Stone Container Corp. v. United States, 229 F.3d 1345, 1350 (Fed. Cir. 2000), none of the language cited by Judge Michel constitutes explicit and carefully considered language regarding the range of equivalents available when a claim amendment gives rise to prosecution history estoppel.

2. Because the Supreme Court has not fully addressed the range of equivalents that is available once prosecution history estoppel applies, we must independently decide the issue. Congress specifically created the Federal Circuit to resolve issues unique to patent law, Markman v. Westview Instruments, Inc., 517 U.S. 370, 390 (1996) (citing H.R. Rep. No. 97-312, pp. 20-23 (1981)), such as those regarding prosecution history estoppel, which is a judicially created doctrine, Hormone Research Found., Inc. v. Genentech, Inc., 904 F.2d 1558, 1564, 15 USPQ2d 1039, 1044 (Fed. Cir. 1990). Congress contemplated that the Federal Circuit would “strengthen the United States patent system in such a way as to foster technological growth and industrial innovation.” Markman, 517 U.S. at 390. Issues such as the one before us in this case are properly reserved for this court to answer with “its special expertise.” Warner-Jenkinson, 520 U.S. at 40 (reserving explicitly for the Federal Circuit the task of formulating the proper test(s) for infringement under the doctrine of equivalents).

The Federal Circuit first addressed the range of equivalents that is available when prosecution history applies in Hughes Aircraft Co. v. United States, 717 F.2d 1351, 219 USPQ 473 (Fed. Cir. 1983) (“Hughes I”). In that case, we recognized that, prior to creation of the Federal Circuit, some regional circuits had followed a flexible bar approach to prosecution history estoppel, whereas others had applied a strict rule of complete surrender when prosecution history estoppel applied. Id. at 1362-63, 219 USPQ at 481-82. We decided to apply prosecution history estoppel as a flexible bar, stating that prosecution history estoppel “may have a limiting effect” on the doctrine of

equivalents “within a spectrum ranging from great to small to zero.” Id. at 1363, 219 USPQ at 481-82.

LaBounty Manufacturing, Inc. v. United States International Trade Commission, 867 F.2d 1572, 9 USPQ2d 1995 (Fed. Cir. 1989), is an example of the flexible bar approach. In LaBounty, we vacated the noninfringement determination of the International Trade Commission (“ITC”) and remanded the case to the ITC for further proceedings because the administrative law judge (“ALJ”) had failed to determine the scope of prosecution history estoppel and had held, instead, that once an element of a claim is amended, no equivalent of that element can be asserted. LaBounty, 867 F.2d at 1576, 9 USPQ2d at 1999. In Black & Decker, Inc. v. Hoover Service Center, 886 F.2d 1285, 1295, 12 USPQ2d 1250, 1258-59 (Fed. Cir. 1989), we held that an amendment made during prosecution did not prevent a finding of infringement under the doctrine of equivalents. We reasoned that although the amendment would bar infringement under the doctrine of equivalents with respect to a device similar to the prior art that had provoked the amendment, prosecution history estoppel did not prevent all applications of the doctrine of equivalents. Id.; see also Dixie USA, Inc. v. Infab Corp., 927 F.2d 584, 588, 17 USPQ2d 1968, 1970-71 (Fed. Cir. 1991) (noting that prosecution history estoppel should not cause “a total preclusion of equivalence”). Similarly, in Modine Manufacturing Co. v. United States International Trade Commission, 75 F.3d 1545, 1555-56, 37 USPQ2d 1609, 1616 (Fed. Cir. 1996), we vacated the ALJ’s holding of lack of infringement under the doctrine of equivalents due to prosecution history estoppel because, although “the available range of equivalency is

limited, by estoppel, . . . the prosecution history and the prior art do not eliminate equivalents.”

Less than a year after Hughes I, however, a five-judge panel of this court decided Kinzenbaw v. Deere & Co., 741 F.2d 383, 222 USPQ 929 (Fed. Cir. 1984). The claimed invention in Kinzenbaw was “[a]n apparatus for forming seed planting furrows.” Id. at 388, 222 USPQ at 932. The claim element at issue related to “a pair of depth gauge compacting wheels” that controlled the depth of the furrow created by the planter. Id. During prosecution, in order to overcome an examiner’s rejection and to obtain his patent, the inventor narrowed his claims by specifying, among other things, that the gauge wheels had to have a radius less than that of the radius of the blades of the planter (called “discs”). Id. On the accused device, the gauge wheels had a radius greater than that of the discs. Id. at 388-89, 222 USPQ at 932. Consequently, the accused device could not literally infringe. As a result, the patentee (Deere) sought to prove infringement under the doctrine of equivalents. Id. at 389, 222 USPQ at 932. The district court concluded that prosecution history estoppel precluded Deere from relying upon the doctrine of equivalents. Id., 222 USPQ at 933. The court determined that, as far as the gauge wheels were concerned, the inventor had intentionally narrowed his claims, and it refused to permit Deere to avoid, through the doctrine of equivalents, the limitation that the inventor had placed on his claims. Id.

On appeal, Deere urged that prosecution history estoppel did not apply because the inventor’s limitation of his claims to devices in which the gauge wheels had a smaller radius than that of the discs was unnecessary to distinguish the prior art. Id. Specifically, Deere contended that only that portion of the claim that provided that the

radius of the gauge wheels had to exceed the distance from the axes of the wheels to the rear edges of the discs was necessary in order to render the claims patentable over the prior art. Id. The five-judge panel rejected Deere's argument. It stated: "We decline to undertake the speculative inquiry whether, if . . . [the inventor] had made only that narrowing limitation in his claim, the examiner nevertheless would have allowed it." Id. The court therefore affirmed the district court's judgment of noninfringement. Id. at 391, 222 USPQ at 934.

The approach to prosecution history estoppel that was followed in Kinzenbaw prompted the following observation by Professor Chisum: "Beginning shortly after its creation in 1982, the Federal Circuit developed two lines of authority on the scope of an estoppel based on an amendment or argument that distinguished the prior art. One line followed a strict approach, according to which a court refused to speculate whether a narrower amendment would have been allowed. The other line followed a flexible or spectrum approach, which recognized that amendments did not invariably preclude all equivalence . . . ." 5A Donald S. Chisum, Chisum on Patents § 18.05[3][b], at 18-492 (1998). Soon after Hughes I and Kinzenbaw were decided they were the subject of comment in the American University Law Review, which annually reviews the work of the Federal Circuit. The commentators stated that the Federal Circuit's "two divergent lines of authority dealing with prosecution history estoppel," the Hughes I line and the Kinzenbaw line, had given rise to ever-increasing "uncertainty and confusion" in patent litigation. Douglas A. Strawbridge et al., Area Summary, Patent Law Developments in the United States Court of Appeals for the Federal Circuit During 1986, 36 Am. U. L. Rev. 861, 887-88 (1987). The commentary that began after Hughes I and Kinzenbaw

were decided has continued. See, e.g., Gregory J. Smith, The Federal Circuit's Modern Doctrine of Equivalents in Patent Infringement, 29 Santa Clara L. Rev. 901, 921 (1989) (noting that there is at least an "apparent conflict" between Hughes I and Kinzenbaw); Note, To Bar or Not to Bar: Prosecution History Estoppel After Warner-Jenkinson, 111 Harv. L. Rev. 2330, 2336 (1998) (stating that the Hughes I line of cases "appear[s] to be irreconcilable" with the Kinzenbaw line of cases).

Since Warner-Jenkinson, panels of this court have continued to visit the question of the range of equivalents that is available after prosecution history estoppel has been determined to exist. Two cases in particular were remanded by the Supreme Court for further consideration in light of Warner-Jenkinson. Honeywell, Inc. v. Litton Sys., Inc., 520 U.S. 1111 (1997); United States v. Hughes Aircraft Co., 520 U.S. 1111 (1997). In Litton Systems, Inc. v. Honeywell, Inc., 140 F.3d 1449, 1455-57, 46 USPQ2d 1321, 1325 (Fed. Cir. 1998), this court determined that Warner-Jenkinson had not changed the "longstanding doctrine that an estoppel only bars recapture of that subject matter actually surrendered during prosecution." The court noted that "the Supreme Court did not reach the question of the proper scope of estoppel for an amended limitation," and thus concluded that Warner-Jenkinson did not affect our already established jurisprudence on the issue. Id. at 1457, 46 USPQ2d at 1327. A similar analysis and conclusion were set forth in Hughes Aircraft Co. v. United States, 140 F.3d 1470, 1476-77, 46 USPQ2d 1285, 1289-90 (Fed. Cir. 1998) ("Hughes II"). The alleged infringer in that case argued that Warner-Jenkinson mandated that prosecution history estoppel act as a complete bar and preclude any finding of infringement under the doctrine of equivalents. Hughes II, 140 F.3d at 1476, 46 USPQ2d at 1289. In rejecting

this argument, this court stated that there must be a determination as to the exact “subject matter the patentee actually surrendered.” Id. at 1476-77, 46 USPQ2d at 1290. Because the accused device did not “fall within the range of subject matter surrendered,” infringement under the doctrine of equivalents was not barred. Id. The court denied rehearing en banc in both Litton and Hughes II, over dissents from the denials. Litton Sys., Inc. v. Honeywell, Inc., 145 F.3d 1472, 47 USPQ2d 1106 (Fed. Cir. 1998); Hughes Aircraft Co. v. United States, 148 F.3d 1384, 47 USPQ2d 1542 (Fed. Cir. 1998).

Both Litton and Hughes II follow the Hughes I flexible bar approach to prosecution history estoppel. In that regard, they are consistent with Professor Chisum’s observation that “[m]ost Federal Circuit panel decisions from 1984 to 1997 followed the flexible approach, which had been initiated in 1983 by the Hughes Aircraft [Hughes I] decision . . . .” Chisum, supra, § 18.05[3][b][i], at 18-497. Nevertheless, this court has neither repudiated Kinzenbaw nor reconciled the inconsistency between the Hughes I and Kinzenbaw lines of authority. Under these circumstances, it is unclear whether in any given case the court will apply the Kinzenbaw approach as opposed to the more generally accepted Hughes I approach. Just as importantly, even if the Hughes I approach is applied, there is uncertainty as to the extent of the surrender that will be held to exist. Thus, Professor Chisum has discussed two Federal Circuit cases, Sun Studs, Inc. v. ATA Equip. Leasing, Inc., 872 F.2d 978, 10 USPQ2d 1338 (Fed. Cir. 1989), and Environmental Instruments, Inc. v. Sutron Corp., 877 F.2d 1561, 11 USPQ2d 1132 (Fed. Cir. 1989), as illustrating the “predictive difficulties of the flexible approach.” Chisum, supra, § 18.05[3][b][ii], at 18-505 to 18-506. In a like vein, it has

been stated that “the criteria used by the court to determine the effect of an estopping amendment have not been set forth in any clear or systematic way” and that “[t]he Federal Circuit’s well-known observation that ‘[d]epending on the nature and purpose of an amendment, it may have a limiting effect from great to small to zero,’ for example, tells little about what the relationship is between the ‘nature and purpose’ of an amendment and its limiting effect.” Ted Apple, Enablement Estoppel: Should Prosecution History Estoppel Arise When Claims Are Amended To Overcome Enablement Rejections?, 13 Santa Clara Computer & High Tech L.J. 107, 128 (1997) (footnotes omitted).

3. Today, we revisit the question we first addressed in Hughes I and come to a different conclusion as to the proper scope of equivalents that is available when prosecution history estoppel applies than we did in that case. We hold that prosecution history estoppel acts as a complete bar to the application of the doctrine of equivalents when an amendment has narrowed the scope of a claim for a reason related to patentability. Our decision to reject the flexible bar approach adopted in Hughes I comes after nearly twenty years of experience in performing our role as the sole court of appeals for patent matters. In those years, the notice function of patent claims has become paramount, and the need for certainty as to the scope of patent protection has been emphasized. A problem with the flexible bar approach is that it is virtually impossible to predict before the decision on appeal where the line of surrender is drawn. The patentee would draw the line just at or slightly short of the prior art, leaving a wide range of equivalents untouched by prosecution history estoppel. The accused infringer, however, would draw the line close to the literal terms of the claims, leaving

little or no range of equivalents. These considerations, we think, contribute to the difficulty under the flexible bar approach in predicting with any degree of certainty the scope of surrender that will be found when prosecution history estoppel applies.

In reaching our holding, we are mindful of the Supreme Court's teaching that binding precedent is not to be lightly discarded. The Court has stated that stare decisis "promotes the evenhanded, predictable, and consistent development of legal principles, fosters reliance on judicial decisions and contributes to the actual and perceived integrity of the judicial process." Payne v. Tennessee, 501 U.S. 808, 827 (1991). The Court also has stated that while from time to time it has overruled governing decisions that are "unworkable or are badly reasoned," it has rarely done so "on grounds not advanced by the parties." United States v. Int'l Bus. Machs. Corp., 517 U.S. 843, 856 (1996) (citations omitted).

We believe that the current state of the law regarding the scope of equivalents that is available when prosecution history estoppel applies is "unworkable." In patent law, we think that rules qualify as "workable" when they can be relied upon to produce consistent results and give rise to a body of law that provides guidance to the marketplace on how to conduct its affairs. After our long experience with the flexible bar approach, we conclude that its "workability" is flawed. Moreover, in overruling Hughes I, we are not acting "on grounds not advanced by the parties." SMC and amici curiae have urged us to follow the strict approach to prosecution history estoppel that we adopt today. In Banc Opening Br. of Defs.-Appellants SMC Corp., et al., at 49-53; see also Br. for Amici Curiae Int'l Bus. Machs. Corp., Eastman Kodak Co., and Ford

Motor Co., at 14-20 (arguing that no range of equivalents should be available for narrowing claim amendments).

We also believe that the flexible bar approach “poses a direct obstacle to the realization of important objectives.” Patterson v. McClean Credit Union, 491 U.S. 164, 173 (1989) (setting forth the “traditional justification[s] for overruling a prior case”). These objectives include giving effect, when prosecution history estoppel arises, to a narrowing amendment’s operation as a disclaimer of subject matter, see, e.g., Exhibit Supply, 315 U.S. at 136-37, preserving the notice function of patent claims, see, e.g., Warner-Jenkinson, 520 U.S. at 29, and promoting certainty in patent law, see, e.g., Markman, 517 U.S. at 390. The realization of these objectives cannot help but be frustrated by the uncertainty inherent in the flexible bar approach.

By making prosecution history estoppel act as a complete bar, we enforce the disclaimer effect of a narrowing claim amendment. By narrowing his claims, a patentee disclaims subject matter encompassed by the original claims. E.g., Exhibit Supply, 315 U.S. at 136-37; Magic City Kennel Club, 282 U.S. at 790; Shepard, 116 U.S. at 598 (noting that a patentee who has narrowed a claim during prosecution cannot “enlarge her patent by argument so as to cover elements not falling within its terms, and which she had explicitly abandoned”). As the Supreme Court has stated, “By amendment [the patentee] recognize[s] and emphasize[s] the difference between the” original claim and amended claim “and proclaim[s] . . . abandonment of all that is embraced in that difference.” Exhibit Supply, 315 U.S. at 136. Amendments “must be strictly construed against the inventor and in favor of the public, and looked upon as in the nature of disclaimers.” Hubbell, 179 U.S. at 83-84. In order to construe such amendments

strictly against the patentee, no scope of equivalents can be afforded to a claim element that was narrowed because of patentability concerns. Although we do not understand older Supreme Court cases to have spoken directly to the question before us, we think the language used in those cases suggesting a strict measurement of the scope of equivalents is consistent with our answer to this question.

Allowing some range of equivalents gives the patentee some benefit of the doubt as to what was disclaimed, a benefit that comes at the public's expense. A complete bar therefore best serves the notice and definitional function of patent claims. "The object of the patent law in requiring the patentee [to specifically define his invention] is not only to secure to him all to which he is entitled, but to apprise the public of what is still open to them." McClain v. Ortmayer, 141 U.S. 419, 424 (1891). But "the doctrine of equivalents, when applied broadly, conflicts with the definitional and public-notice functions of the statutory claiming requirement." Warner-Jenkinson, 520 U.S. at 29. If prosecution history estoppel acts as a complete bar to application of the doctrine of equivalents, both the patentee and the public are on notice as to the scope of protection provided by a claim element narrowed for a reason related to patentability. The patentee and the public can look to the prosecution history, a public record, to determine if any prosecution history estoppel arises as to any claim element. If so, that element's scope of protection is clearly defined by its literal terms.

The Supreme Court recognized the value of a complete bar in Warner-Jenkinson when it discussed the presumption that prosecution history estoppel applies when an amendment is unexplained. The Court, keeping in mind "that claims do indeed serve both a definitional and a notice function," held that if the presumption was not rebutted,

“prosecution history estoppel would bar the application of the doctrine [of] equivalents as to that element.” Id. at 33 (emphasis added); see also infra Answer to En Banc Question 4. A complete bar to the doctrine of equivalents for unexplained amendments would give, as the Court stated, “proper deference to the role of claims in defining an invention and providing public notice,” Warner-Jenkinson, 520 U.S. at 33. A complete bar similarly serves the definitional and notice functions when explained amendments give rise to prosecution history estoppel. Regardless of whether the amendment is explained or unexplained, if the amendment narrows the scope of the claim for a reason related to patentability, a complete bar to the doctrine of equivalents provides the public and the patentee with definite notice as to the scope of the claimed invention.

A complete bar also eliminates the public’s need to speculate as to the subject matter surrendered by an amendment that narrows a claim for a reason related to patentability. There are several aspects of the prosecution history estoppel inquiry where speculation is not allowed. The Supreme Court has noted that we need not inquire into the correctness of the examiner’s rejection that led to a claim amendment. Warner-Jenkinson, 520 U.S. at 33 n.7 (citing Magic City Kennel Club, 282 U.S. at 789-90). Even if the rejection is improper, the amendment may still give rise to prosecution history estoppel. Id. In addition, we do not speculate as to whether any given amendment was material to the prosecution of the patent because “[t]he patentee makes them all material by the restricted form of his claim.” Hubbell, 179 U.S. at 84 (citations omitted). In view of the reluctance to entertain speculative inquiries in other aspects of prosecution history estoppel, a speculative inquiry should not be required to

determine the scope of equivalents still available for a claim element narrowed for a reason related to patentability. A complete bar avoids such an inquiry.

Under the flexible bar approach, however, the exact range of equivalents when prosecution history estoppel applies is virtually unascertainable, with only the prior art marking the outer limits of the claim's scope. There is no precise metric to determine what subject matter was given up between the original claim and the amended claim. Consider, for example, a claim that originally recited a value "less than twenty" that was amended to recite a value "less than five" in light of a rejection over prior art disclosing a value of fifteen.<sup>2</sup> What subject matter was abandoned under the flexible approach? Is the patentee limited to values that are closer to five than fifteen, or can he reach any value less than fifteen? Can the patentee encompass by equivalents a value of ten, or would that recapture part of the surrendered subject matter? Put simply, it is impossible, even under this basic example, for the public or the patentee to determine the precise range of equivalents available under the flexible bar approach. This creates a "zone of uncertainty which enterprise and experimentation may enter only at the risk of infringement claims . . . [and which] discourage[s] invention only a little less than unequivocal foreclosure of the field." Markman, 517 U.S. at 390 (quoting United Carbon Co. v. Binney & Smith Co., 317 U.S. 228, 236 (1942)). "The public [would] be deprived of rights supposed to belong to it, without being clearly told what it is that limits these rights." Markman, 517 U.S. at 390 (quoting Merrill v. Yeomans, 94 U.S. 568, 573 (1876)).

---

<sup>2</sup> A similar problem presents itself under the facts of Warner-Jenkinson, where the claim was amended to recite an upper pH limit of 9.0 to overcome prior art disclosing a pH above 9.0. Warner-Jenkinson, 520 U.S. at 32.

A complete bar, unlike a flexible bar, thus lends certainty to the process of determining the scope of protection afforded by a patent. With a complete bar, both the public and the patentee know that once an element of a claim is narrowed by amendment for a reason related to patentability, that element's scope of coverage will not extend beyond its literal terms. There is no speculation or uncertainty as to the exact range of equivalents that might be available. This certainty aids both the public and the patentee in ascertaining the true scope and value of the patent without having to resort to litigation to obtain a case by case analysis of what subject matter the claims can cover. With a complete bar, neither the public nor the patentee is required to pay the transaction costs of litigation in order to determine the exact scope of subject matter the patentee abandoned when the patentee amended the claim.

Thus, under the complete bar approach, technological advances that would have lain in the unknown, undefined zone around the literal terms of a narrowed claim under the flexible bar approach will not go wasted and undeveloped due to fear of litigation. The public will be free to improve on the patented technology and design around it without being inhibited by the threat of a lawsuit because the changes could possibly fall within the scope of equivalents left after a claim element has been narrowed by amendment for a reason related to patentability. This certainty will stimulate investment in improvements and design-arounds because the risk of infringement will be easier to determine. In general, the difficulty in counseling the public and the patentee on the scope of protection provided by an amended element is greatly reduced under the complete bar approach due to the certainty and predictability such a bar produces.

Finally, we see no overriding benefit to the flexible bar approach. Although a flexible bar affords the patentee more protection under the doctrine of equivalents, we do not believe that the benefit outweighs the costs of uncertainty. The Supreme Court noted in Warner-Jenkinson that the doctrine of equivalents has “taken on a life of its own, unbounded by the patent claims.” Warner-Jenkinson, 520 U.S. at 28-29. A complete bar reins in the doctrine of equivalents, making claim scope more discernible and preserving the notice function of claims. The Court indicated that the application of a complete bar allowed prosecution history estoppel to place “reasonable limits on the doctrine of equivalents, and further insulate[] the doctrine from any feared conflict with the Patent Act.” Id. The application of a complete bar to the doctrine of equivalents whenever a claim amendment gives rise to prosecution history estoppel similarly reduces the conflict and tension between the patent protection afforded by the doctrine of equivalents and the public’s ability to ascertain the scope of a patent.

D. Question 4

When “no explanation [for a claim amendment] is established,” Warner-Jenkinson, 520 U.S. at 33, 117 S. Ct. 1040, thus invoking the presumption of prosecution history estoppel under Warner-Jenkinson, what range of equivalents, if any, is available under the doctrine of equivalents for the claim element so amended?

We answer Question 4 as follows: When no explanation for a claim amendment is established, no range of equivalents is available for the claim element so amended.

This question is answered by Warner-Jenkinson:

Where no explanation is established, . . . prosecution history estoppel would bar the application of the doctrine [of] equivalents as to that element.

Warner-Jenkinson, 520 U.S. at 33 (emphasis added). In answering this question, we affirm what we stated in Sextant, 172 F.3d at 832, 49 USPQ2d at 1875: when “the Warner-Jenkinson presumption is applicable, . . . the prosecution history estoppel arising therefrom is total and completely ‘bars’ the application of the doctrine of equivalents as to the amended limitation.”

E. Question 5

Would a judgment of infringement in this case violate Warner-Jenkinson's requirement that the application of the doctrine of equivalents “is not allowed such broad play as to eliminate [an] element in its entirety,” 520 U.S. at 29, 117 S. Ct. 1040. In other words, would such a judgment of infringement, post Warner-Jenkinson, violate the “all elements” rule?

We do not need to reach this question for reasons which will become clear in our discussion of the specific case before us. Accordingly, we leave for another day any discussion of the “all elements” rule.

IV. Infringement of Festo's Patents

Festo is the owner by assignment of the Stoll patent and the Carroll patent, both of which are directed to magnetically coupled rodless cylinders. Festo sued SMC in the United States District Court for the District of Massachusetts, alleging infringement of the patents. The jury found that SMC infringed the Stoll patent under the doctrine of equivalents and assessed damages accordingly. Festo Corp. v. Shoketsu Kinzoku Kogyo Kabushiki Co., No. 88-1814-PBS, slip op. at 2-3 (D. Mass. Oct. 27, 1994) (Judgment) (“Festo I (Judgment)”). The district court previously had granted Festo's motion for summary judgment that certain models of SMC's rodless cylinders infringed the Carroll patent, also under the doctrine of equivalents. Festo Corp. v. Shoketsu

Kinzoku Kogyo Kabushiki Co., No. 88-1814-PBS, slip op. at 14-15 (D. Mass. July 11, 1994) (Order) (“Festo I (Order)”).<sup>3</sup>

A. The Patents and Technology at Issue

Both the Stoll patent and the Carroll patent disclose magnetic rodless cylinders. The claimed devices are composed of three basic parts: a piston, a cylinder, and a sleeve. In basic terms, the piston is on the inside of the cylinder, and is moved by fluid under pressure. The sleeve is on the outside of the cylinder, and is magnetically coupled to the piston. The magnetic attraction between the sleeve and the piston causes the sleeve to follow the piston when it moves along the inside of the cylinder. The sleeve is used to move objects on a conveying system.

1. The application for the Stoll patent was filed on May 28, 1980; the patent issued on October 12, 1982. The following figure, the only drawing in the patent, shows the sleeve (18), the cylinder (10),<sup>3</sup> and the piston (16) of the Stoll device:

---

<sup>3</sup> On the first appeal to this court, the panel affirmed the judgment of infringement under the doctrine of equivalents of both the Stoll and Carroll patents. Festo Corp. v. Shoketsu Kinzoku Kogyo Kabushiki Co., 72 F.3d 857, 37 USPQ2d 1161 (Fed. Cir. 1995) (“Festo II”). After that decision, the Supreme Court decided Warner-Jenkinson. SMC had petitioned the Court for a writ of certiorari, which the Court granted, vacating the judgment and remanding the case to this court for further consideration in light of Warner-Jenkinson (a sequence of events called a “GVR”). Festo III, 520 U.S. at 1111. On remand, a panel of this court again affirmed the district court’s judgment of infringement under the doctrine of equivalents. Festo Corp. v. Shoketsu Kinzoku Kogyo Kabushiki Co., 172 F.3d 1361, 50 USPQ2d 1385 (Fed. Cir. 1999) (“Festo IV”). SMC then petitioned for rehearing en banc, which we granted. Festo V, 187 F.3d at 1381, 51 USPQ2d at 1959.

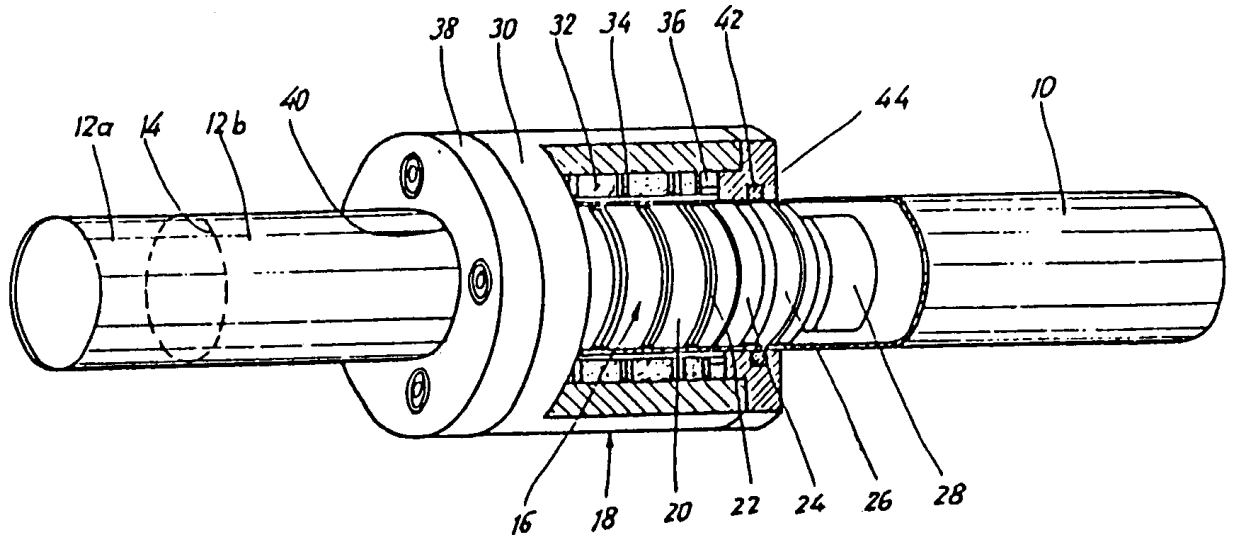

Inside the cylinder, the piston is driven by a pressurized fluid. Stoll patent, col. 3, ll. 13-19. As the piston travels through the cylinder, the magnetically coupled sleeve follows the piston along the outside of the cylinder. Id.

The piston includes magnets (20) and two “elastomeric sealing rings” (26). Id. at col. 3, ll. 20-32. The sealing rings prevent any impurities from getting on the piston. Id. at col. 3, ll. 48-55. There also are a pair of “guide rings” (24) on the piston. Id. at col. 3, ll. 26-30. As the patent explains, the guide rings, which project beyond the piston’s surface, “pass along the internal [cylinder] surface in a sliding fit,” id. at col. 3, ll. 29-30, and help prevent impurities from dirtying the piston, id. at col. 3, ll. 51-55.

The sleeve of the Stoll patent device is made of multiple parts that include magnets (32) and an outer body made of a magnetizable material (30). Id. at col. 3, ll. 60-65. According to the patent, the magnetizable material on the sleeve that encircles the sleeve’s magnets allows “magnetic leakage fields in the vicinity of the driven assembly to be kept to a minimum,” preventing any unwanted braking forces. Id. at col. 2, ll. 24-35.

Claim 1 of the Stoll patent is representative of the claims asserted by Festo, and is the only claim of the Stoll patent at issue on appeal:

1. In an arrangement having a hollow cylindrical tube and driving and driven members movable thereon for conveying articles, the improvement comprising

- wherein said tube is made of a nonmagnetic material,
- wherein said driving member is a piston movably mounted on the inside of said tube, said piston having a piston body and plural axially spaced, first permanent annular magnets encircling said piston body,
- said piston further including first means spacing said first permanent magnets in said axial spaced relation, the radially peripheral surface of said magnets being oriented close to the internal wall surface of said tube,
- said piston further including plural guide ring means encircling said piston body and slidably engaging said internal wall and
- first sealing rings located axially outside said guide rings for wiping said internal wall as said piston moves along said tube to thereby cause any impurities that may be present in said tube to be pushed along said tube so that said first annular magnets will be free of interference from said impurities,
- wherein said driven member includes a cylindrical sleeve made of a magnetizable material and encircles said tube,
- said sleeve having plural axially spaced second permanent annular magnets affixed thereto and in magnetically attracting relation to said first permanent annular magnets,
- and second means spacing said second permanent annular magnets in said axially spaced relation, the radially inner surface of said magnets being oriented close to the external surface of said tube,
- said sleeve having end face means with second sealing rings located axially outside said second permanent annular magnets for wiping the external wall surface of said tube as said driven member is moved along said tube in response to a driving movement of said piston to thereby cause any impurities that may be present on said tube to be pushed along said tube so that said second permanent annular magnets will be free of interference from said impurities.

Stoll patent, col. 5, l. 23 - col. 6, l. 18 (paragraphing added).

2. The application for the Carroll patent was filed on February 17, 1972; the patent issued on December 18, 1973. A reexamination certificate was issued on October 25, 1988, with amended claims. The Carroll patent is directed to the same

technology as the Stoll patent. An exterior view of the Carroll patent device is shown in Figure 1 of the Carroll patent, reproduced below:

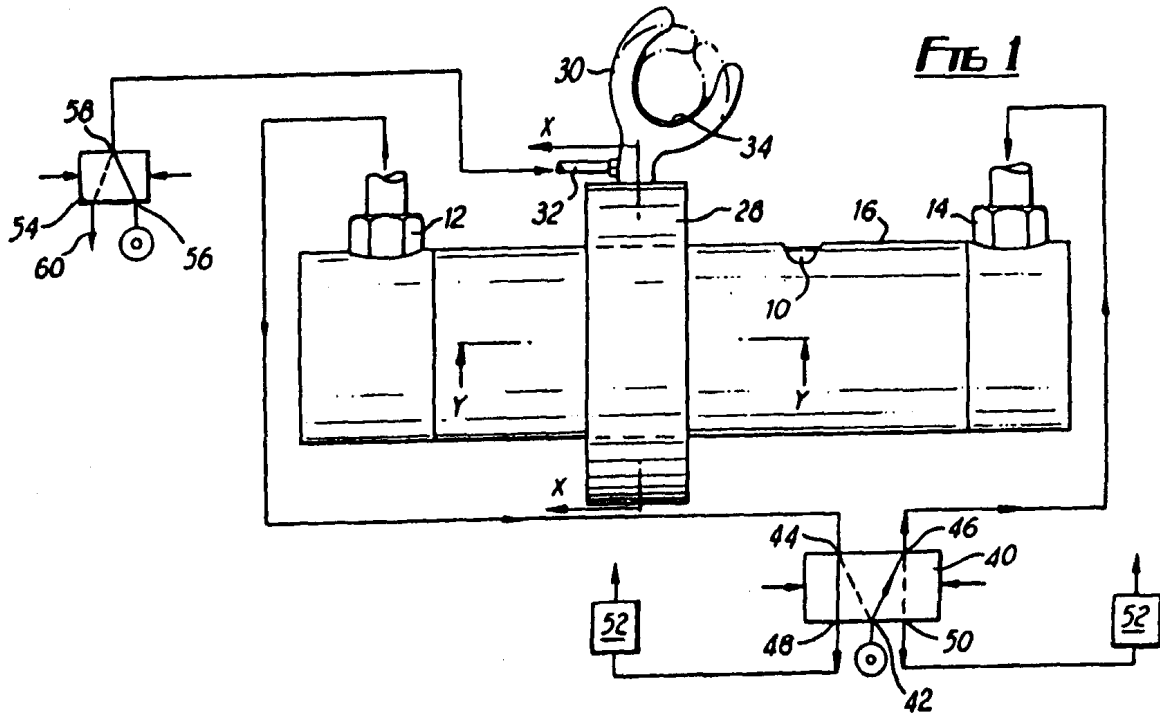

In the disclosed embodiment, the sleeve (28) is described as a permanent magnet that is attached to a gripping device (30) and that surrounds part of the exterior of the cylinder (10). Carroll patent, col. 2, ll. 17-26. As in the device of the Stoll patent, the sleeve of the Carroll patent moves along the cylinder in response to a magnetic piston which moves inside the cylinder. *Id.* Each end of the piston has a sealing ring set in an annular groove. *Id.* at col. 2, ll. 1-16. According to the patent, the sealing rings “engage the inner wall of the cylinder and form a fluid tight seal” that allows compressed air, or any other pressurized fluid, injected into port (12) or (14) on the outside of the cylinder to move the piston in either direction. *Id.* at col. 2, ll. 10-16, 42-59. The polarization of the magnets on the piston and the sleeve causes the sleeve,

which is located on the outside of the cylinder, to follow the movement of the piston, which is located on the inside of the cylinder. Id. at col. 2, ll. 17-24.

Claim 9 of the reexamined Carroll patent is representative of the claims asserted by Festo:

9. A device for moving articles, which comprises:  
a hollow cylinder formed of non-ferrous material and having opposite axial ends;  
a piston mounted in the interior of the hollow cylinder and reciprocatingly slidable therein, the piston including a central mounting member disposed axially in the cylinder,  
a plurality of cylindrically-shaped permanent magnets mounted on the central mounting member and spaced apart axially from each other, each magnet having a bore formed axially there-through for receiving the central mounting member,  
at least one pair of end members mounted on the central mounting member and disposed on opposite axial sides of the plurality of magnets,  
a pair of cushion members formed of resilient material, the cushion members being situated near opposite axial ends of the central mounting member to help prevent damage to the piston when the piston contacts an axial end of the cylinder,  
and a pair of resilient sealing rings situated near opposite axial ends of the central mounting member and engaging the cylinder to effect a fluid-tight seal therewith;  
a body mounted on the exterior of the hollow cylinder and reciprocatingly slidable thereon,  
the body including a plurality of annularly shaped permanent magnets surrounding the cylinder and spaced apart from each other, the permanent magnets of the piston and body being polarized so as to magnetically couple the body to the piston whereby movement of the piston inside the cylinder causes a corresponding movement of the body outside the cylinder,  
the body further including means provided thereon for holding on the body an article to be moved; and  
means for controlling the admission of pressure fluid into the cylinder and exhaust fluid from the cylinder for moving the piston in the cylinder,  
the attractive forces between the permanent magnets of the piston and the body being such that movement of the piston causes corresponding movement of the body below a predetermined load on the body and such that above said predetermined load movement of the piston does not cause corresponding movement of the body.

Reexamined Carroll patent, col.1, l. 34 - col. 2, l. 37 (additional paragraphing added).

3. The SMC devices that were found to infringe the Stoll and Carroll patents under the doctrine of equivalents have two notable differences from the structures claimed in the patents. First, the SMC devices, although having pistons with two hard plastic guide rings, have only a single resilient two-way sealing ring, located on one end of the pistons. Thus, while the patents disclose and claim devices with a pair of sealing rings, the SMC devices have only single two-way sealing rings.<sup>4</sup> Second, the outer portion of the sleeves of SMC's devices is made of an aluminum alloy, a material that the parties agree is not a magnetizable material. Thus, while the Stoll patent discloses and claims a sleeve made of a magnetizable material, the SMC devices have sleeves that are not made of a magnetizable material.

#### B. Prosecution History of the Patents at Issue

1. The Stoll patent application was filed in the United States as the U.S. counterpart of a German patent application. As filed, claim 1 of the Stoll patent initially read:

1. A linear motor for use in a conveying system,  
said motor being operable by a pressure medium and comprising a  
tubular part connectible to a source of the pressure medium,  
a piston which is slidable in said tubular part and which has sealing  
means at each end for [w]iping engagement with an internal surface of the  
tubular part and so as to form a seal for the pressure medium,  
and a driven assembly which is slidable on the tubular part and  
which has means at each end for [w]iping engagement with an external  
surface of the tubular part,  
the piston and the driven assembly each carrying a drive magnet  
arrangement in the form of a hollow cylindrical assembly,

---

<sup>4</sup> A sealing ring has a lip on only one side of the ring that seals against fluid flow on that side. By contrast, a two-way sealing ring has a lip on both sides of the ring that allows each side to seal against fluid flow.

each magnet arrangement having radial play relative to the adjacent surface of the tubular part,  
and surfaces of the magnet arrangements which face the tubular part being closely adjacent to the respective surfaces of the tubular part.

The original application also included two dependent claims of relevance, claims 4 and 8:

4. A linear motor according to any of claims 1 to 3, wherein the sealing means of the piston comprise sealing rings and the piston is provided with sliding guide rings near the sealing rings.

8. A linear motor according to any of the preceding claims wherein the driven assembly is provided with a sleeve made of a magnetisable material, which encircles the hollow cylindrical assembly of the magnet arrangement.

(Emphasis added.)

In the first Office Action, the patent examiner rejected all twelve original claims, and cited three patents as references “believed pertinent.” Claims 1-12 were rejected under 35 U.S.C. § 112, ¶ 1, because the “exact method of operation is unclear. Is [the] device a true motor or magnetic clutch?” In addition, claims 4-12 were rejected under 35 U.S.C. § 112, ¶ 2, because they were “improperly multiply dependent.”

In response, Stoll amended some claims, including claim 1, and canceled others, including claims 4 and 8. Claim 1 was amended to recite “plural guide ring means . . . and first sealing rings located axially outside said guide rings” on the piston and to recite “a cylindrical sleeve made of a magnetizable material.” In the remarks accompanying the amendments, Stoll stated that “[e]ach of the claims now present in this application has been reviewed for compliance with the provisions of Title 35 USC 112. Accordingly, further consideration of these claims, particularly with respect to the provisions of Title 35 USC 112, is respectfully solicited.”

When Stoll submitted this amendment, he also made two German patents of record in the application, No. 27,37,924 and No. 19,82,379. Stoll had received these patents in the first office action in the corresponding German application. Stoll argued in the remarks accompanying the amendment that the “claims now present in th[e] application” are distinguishable over these references. Stoll stated that “[i]t is clear that neither of these two references discloses the use of structure preventing the interference by impurities located inside the tube and on the outside of the tube while the arrangement is moved along the tube.”

After considering this response, the examiner allowed the amended claims, requesting that all references to “linear motors” be deleted from the specification, because this phrase “connotes a different device having different operational characteristics.”

2. The relevant portion of the Carroll patent’s prosecution history is its reexamination. Before reexamination, claim 1 of the Carroll patent read as follows:

1. A device for moving articles comprising  
a cylinder of non-ferrous material,  
a piston including a permanent magnet having a pole-piece on each axial side thereof,  
a body disposed outside and adjacent to said cylinder, said body including a permanent magnet which substantially surrounds the cylinder, there being a pole piece on each axial side of the permanent magnet included in said body, and  
means for controlling the admission of pressure fluid into the cylinder and exhaust of fluid from the cylinder for moving the piston in the cylinder,  
the attractive forces between the permanent magnets being such that movement of the piston causes corresponding movement of the body below a predetermined load on the body and such that above said predetermined load movement of the piston does not cause corresponding movement of the body.

Original Carroll patent, col. 4, ll. 4-19 (paragraphing added). This claim did not recite the sealing rings disclosed in the specification.

Carroll requested reexamination on March 18, 1988, citing German Patent No. 1,982,379, which was not of record in the Carroll patent's prosecution history. In his request for reexamination, Carroll asserted that the German patent presented a substantial new question of patentability because the Patent Office "may find the German patent, in combination with the other references which were cited during prosecution of the Carroll patent[,] . . . to disclose several of the primary structural features of the device defined by Claim 1."

The German patent described rodless cylinders having several of the features of the device described in the Carroll patent, including a pair of sealing rings. The Patent Office granted Carroll's request for reexamination, finding that the German patent "discloses an article transport device which is movable in response to a hydraulically operated magnetic piston, which is a feature that was not found by the Examiner during the prosecution" of the Carroll patent.

During reexamination, Carroll canceled claim 1 and added claim 9, which explicitly recites "a pair of resilient sealing rings situated near opposite axial ends of the central mounting member and engaging the cylinder to effect a fluid-tight seal therewith." In the remarks accompanying the amendment, Carroll argued that the now-amended claims<sup>5</sup> "more clearly and more specifically" define the "features of the patentee's invention that distinguish over the art of record, including" the German patent cited in the request for reexamination. Carroll also noted that the structure now

---

<sup>5</sup> Carroll also amended claims 3 and 5 to depend from claim 9.

described in claim 9 was not disclosed in the art of record. Carroll further stated that “the particular structure of the inner piston and outer body now specifically set forth in new claim 9 is not taught or suggested by the German patent,” particularly noting the recitation of the placement and plurality of magnets for both the piston and outer body and the recitation of resilient materials and cushion materials on the ends of the piston.

The examiner allowed the amended claims, stating that “the prior art does not teach or render obvious the claimed combination which includes the plurality of magnets, end members, and cushion members in the claimed relationship.”

### C. The District Court Proceedings

Festo sued SMC in the district court for infringement of both the Stoll and Carroll patents. Festo’s claims of infringement and damages and SMC’s counterclaims of invalidity were referred to a special master for consideration. The special master determined that both the Stoll and Carroll patents were not invalid. Festo Corp. v. Shoketsu Kinzoku Kogyo Kabushiki Co., No. 88-1814-MA, slip op. at 42, 19 (D. Mass. Spec. Master Apr. 27, 1993) (Report). The special master also determined that the SMC devices at issue in this appeal did not infringe the Stoll patent, id. at 42, 47, but did infringe claims 5, 6, and 9 of the Carroll patent under the doctrine of equivalents, id. at 25.

In due course, the district court entertained summary judgment motions from both parties on the issues of infringement and validity. Festo I (Order), slip op. at 1-3. The district court denied all summary judgment motions except Festo’s motion for summary judgment of infringement of the Carroll patent. Id. at 2. In ruling on the motions, the district court determined that SMC could not literally infringe the Stoll

patent because SMC's devices did not have magnetizable sleeves. Id. at 6. The court also determined that there was a genuine issue of material fact regarding infringement under the doctrine of equivalents. Id. at 11. The court addressed SMC's assertion that prosecution history estoppel barred the application of the doctrine of equivalents to the Stoll patent because the magnetizable sleeve element was not initially recited in claim 1, but was added to the claim after the first Office Action. Id. at 9-10. The court concluded that the reason for the magnetizable sleeve amendment was "a mystery," because it did not appear to be related to any of the examiner's 35 U.S.C. § 112 rejections, and it did not appear to distinguish the invention over the prior art. Id. at 10. The district court therefore declined to hold that prosecution history estoppel barred a finding that the Stoll patent was infringed under the doctrine of equivalents. Id. at 11.

Turning to the Carroll patent, the court noted that the only argument of noninfringement that SMC made was that the single sealing ring in its piston was not equivalent to the pair of sealing rings recited in claim 9 of the Carroll patent. Id. at 14. However, Festo had presented expert testimony that SMC's single seal was equivalent to the two seals recited in the claims. Id. at 14. To rebut this testimony, SMC cited a statement Stoll had made during prosecution of the Stoll patent to the effect that two sealing rings are necessary to prevent dirt on the piston's magnet. Id. at 14-15. The district court found that the statement made during prosecution of the Stoll patent did not bear on the "meaning and function of the sealing rings as described" in the Carroll patent. Id. at 14-15. The court therefore granted Festo's motion for summary judgment of infringement of claims 5, 6, and 9 of the Carroll patent under the doctrine of equivalents. Id. at 16.

The remaining issues, infringement under the doctrine of equivalents of the Stoll patent, and validity of the Carroll and Stoll patents, were tried to a jury. Festo I (Judgment), slip op. at 1. The jury rendered a verdict on July 14, 1994, concluding that both patents were not invalid and finding that claim 1 of the Stoll patent was infringed under the doctrine of equivalents. Id. at 2-3. The special verdict form indicates that the jury found that Festo had proven by a preponderance of the evidence that SMC's non-magnetizable sleeve and single sealing ring performed substantially the same function in substantially the same way to obtain substantially the same result as the claimed magnetizable sleeve and pair of sealing rings. Festo Corp. v. Shoketsu Kinzoku Kogyo Kabushiki Co., No. 88-1814-PBS (D. Mass. July 14, 1994) (Special Verdict Form) ("Festo I (Special Verdict Form)").

#### D. SMC's Appeal

SMC appeals the judgment of infringement of the Stoll patent, which was entered pursuant to the jury's verdict that the patent was infringed under the doctrine of equivalents. Infringement under the doctrine of equivalents is a question of fact. Warner-Jenkinson, 520 U.S. at 38. We must overturn the jury's finding on a factual issue if it is not supported by substantial evidence or if it is based on an erroneous legal determination. Kearns v. Chrysler Corp., 32 F.3d 1541, 1547-48, 31 USPQ2d 1746, 1751 (Fed. Cir. 1994). Prosecution history estoppel is a legal question that is subject to de novo review by this court. LaBounty, 867 F.2d at 1576, 9 USPQ2d at 1998. Thus, when reviewing the jury verdict, we will independently decide the legal question of the application of prosecution history estoppel to the Stoll patent.

SMC also appeals the district court's judgment of infringement of the Carroll patent, which was entered in accordance with the court's grant of Festo's motion for summary judgment that claims 5, 6 and 9 were infringed under the doctrine of equivalents. Summary judgment "shall be rendered forthwith if the pleadings, depositions, answers to interrogatories, and admissions on file, together with the affidavits, if any, show that there is no genuine issue as to any material fact and that the moving party is entitled to a judgment as a matter of law." Fed. R. Civ. P. 56(c); Vivid Techs., Inc. v. Am. Sci. & Eng'g, Inc., 200 F.3d 795, 806-07, 53 USPQ2d 1289, 1297 (Fed. Cir. 1999). We review the grant of a motion for summary judgment without deference, Conroy v. Reebok, Int'l, Ltd., 14 F.3d 1570, 1575, 29 USPQ2d 1373, 1377 (Fed. Cir. 1994), drawing all reasonable factual inferences in favor of the non-moving party, Anderson v. Liberty Lobby, Inc., 477 U.S. 242, 255 (1986); Semiconductor Energy Lab. Co. v. Samsung Elecs. Co., 204 F.3d 1368, 1378, 54 USPQ2d 1001, 1008 (Fed. Cir. 2000).

1. When infringement is alleged to occur under the doctrine of equivalents, two primary legal limitations on the doctrine "are to be determined by the court, either on a dispositive pretrial motion or on a motion for judgment as a matter of law at the close of evidence and after the jury verdict." Warner-Jenkinson, 520 U.S. at 39 n.8. Those legal limitations are prosecution history estoppel and the "all elements" rule. Id.

The first legal limitation a court should consider is prosecution history estoppel, because prosecution history estoppel may completely bar the application of the doctrine of equivalents to a given claim element. The first step in a prosecution history estoppel analysis is to determine which claim elements are alleged to be met by equivalents.

Then, the court must determine whether the elements at issue were amended during prosecution of the patent. If they were not, amendment-based estoppel will not bar the application of the doctrine of equivalents. However, the court still may need to consider whether statements made during prosecution give rise to argument-based estoppel. See e.g., Pharmacia & Upjohn, 170 F.3d at 1377, 50 USPQ2d at 1036.

If the claim elements at issue were amended, the court first must determine whether the amendment narrowed the literal scope of the claim. If so, prosecution history estoppel will apply unless the patent holder establishes that the amendment was made for a purpose unrelated to patentability. Warner-Jenkinson, 520 U.S. at 40-41. If the patent holder fails to do so, prosecution history estoppel will bar the application of the doctrine of equivalents to that claim element.

In Warner-Jenkinson, the Supreme Court explained the purpose of placing on the patent holder the burden of establishing the reason for an amendment: allocating the burden in this manner “gives proper deference to the role of claims in defining an invention and providing public notice.” Id. at 33. Public notice considerations also have been fundamental to our decisions regarding the scope of prosecution history estoppel. E.g., Pharmacia & Upjohn, 170 F.3d at 1377, 50 USPQ2d at 1036 (“To determine what subject matter has been relinquished, an objective test is applied, inquiring whether a competitor would reasonably believe that the applicant had surrendered the relevant subject matter.” (citation and quotations omitted)). In order to give due deference to public notice considerations under the Warner-Jenkinson framework, a patent holder seeking to establish the reason for an amendment must base his arguments solely upon the public record of the patent’s prosecution, i.e., the patent’s prosecution history.

To hold otherwise—that is, to allow a patent holder to rely on evidence not in the public record to establish a reason for an amendment—would undermine the public notice function of the patent record. If the reasons for the amendment do not appear in the public record of the patent’s prosecution, the reasons in most cases will be known only to the patent holder. We therefore hold that a narrowing amendment will give rise to prosecution history estoppel unless the prosecution history of the patent reveals that the amendment was made for a purpose unrelated to patentability concerns.<sup>6</sup>

If prosecution history estoppel does not bar the application of the doctrine of equivalents, the court should consider the second legal limitation on the doctrine, the “all elements” rule, *see, e.g., Pennwalt Corp. v. Durand-Wayland, Inc.*, 833 F.2d 931, 4 USPQ2d 1737 (Fed. Cir. 1987) (en banc) (holding that there can be no infringement under the doctrine of equivalents if even one element of a claim or its equivalent is not present in the accused device). If the court determines that a finding of infringement under the doctrine of equivalents “would entirely vitiate a particular claim element,” then

---

<sup>6</sup> In her dissenting opinion, Judge Newman expresses the concern that we are penalizing the patent holder by limiting the evidence upon which he can rely to establish that a narrowing amendment was made for a purpose unrelated to patentability to what is contained in the prosecution history record. In response, we wish to make it clear that, in determining the reason for an amendment, a court can properly consider any attorney argument regarding the reason for the amendment that is supported by the prosecution history record. Permitting patent holders to rely on evidence extrinsic to the prosecution history record would undermine the public notice function of the patent record. In *Warner-Jenkinson*, the Supreme Court required that a patent holder be provided an opportunity to “demonstrate[] that an amendment required during prosecution had a purpose unrelated to patentability.” *Warner-Jenkinson*, 520 U.S. at 40-41. The Court, however, did not discuss the evidence that patent holders can use in that regard. Thus, restricting the evidence to the prosecution history record does not run counter to *Warner-Jenkinson*.

the court should rule that there is no infringement under the doctrine of equivalents. Warner-Jenkinson, 520 U.S. at 39 n.8.

2. The jury found that claim 1 of the Stoll patent was infringed under the doctrine of equivalents. Festo I (Special Verdict Form). The two elements found to be infringed by equivalents were the “cylindrical sleeve made of a magnetizable material,” and the “first sealing rings located axially outside . . . [the] guide rings.” Id. Both of these elements were added during prosecution of the patent. Following the methodology outlined above, we conclude that prosecution history estoppel bars the application of the doctrine of equivalents to these claim elements. In view of this determination, we do not reach the “all elements” rule.

We begin our analysis with the magnetizable sleeve element. SMC argues that this claim element is not entitled to any range of equivalents. SMC contends that Festo has not demonstrated that the amendment was made for a reason unrelated to patentability and that, therefore, the presumption of Warner-Jenkinson applies and the doctrine of equivalents is barred. SMC asserts that the voluntary nature of the amendment is irrelevant to the prosecution history estoppel inquiry because Warner-Jenkinson places the burden on a patent holder to establish the reason for an amendment, regardless of whether the amendment was required or voluntary. SMC argues that Festo disclaimed non-magnetizable sleeves when it amended the claim to recite a magnetizable sleeve. SMC also argues that the public, including competitors like itself, would reasonably understand from the prosecution history of the patent that Festo had surrendered any device with a non-magnetizable sleeve.

Festo responds that the Warner-Jenkinson presumption does not apply to voluntary amendments. Festo emphasizes that the magnetizable sleeve amendment was not made in response to any prior art rejection and was not needed to overcome the 35 U.S.C. § 112 rejections of the original claims. Accordingly, Festo argues, prosecution history does not bar the application of the doctrine of equivalents to this claim element.

To determine whether a claim amendment gives rise to prosecution history estoppel, we first must determine whether the amendment narrowed the literal scope of the claim. Here we are presented with the situation where the added claim element was introduced through a new claim, instead of through an amendment to an original claim. Nevertheless, the addition of the magnetizable sleeve claim element can be said to have narrowed the scope of the original claim because the new claim replaced the original claim. Specifically, the only original independent claim, which did not recite a magnetizable sleeve, was replaced with an independent claim which does recite a magnetizable sleeve. Because the amendment narrowed the literal scope of the claim, we must determine whether Festo has established that it was made for a reason unrelated to patentability.

We agree with SMC that the reason for the amendment adding the magnetizable sleeve element is not evident from the prosecution history. Original claim 1 did not recite a magnetizable sleeve, although this feature of the invention was recited in original dependent claim 8. In response to the first Office Action, Festo replaced original claim 1 with a claim reciting a magnetizable sleeve and canceled claim 8. Although the amendment was submitted in the response to the first Office Action, the

amendment itself was not responsive to any of the rejections set forth in the Office Action. As discussed above, the Office Action rejected all of the claims under 35 U.S.C. § 112, ¶ 1 because it was not clear to the examiner whether the claimed device was a true motor or a magnetic clutch; in addition, the Office Action rejected claims 4-12 under 35 U.S.C. § 112, ¶ 2 for being improperly multiply dependent. The amendment adding the magnetizable sleeve element did not address either of these rejections. Moreover, there is no statement in the prosecution history that explains why this element was included in the independent claim.

In its Supplemental Brief On Remand from the Supreme Court, Festo argued that the amendment was made to clarify the claim. Specifically, Festo asserted that the “hollow cylindrical assembly” recited in original claim 1 was “rewritten more clearly as ‘a cylindrical sleeve made of a magnetizable material.’” Appellee’s Supplemental Brief On Remand from the United States Supreme Court, at 7. This assertion is inadequate to escape the Warner-Jenkinson presumption, however, because nothing in the prosecution history of the Stoll patent indicates that the magnetizable sleeve element was merely added for purposes of clarification unrelated to patentability concerns.

On remand, Festo also argued that the voluntary nature of the amendment that added the magnetizable sleeve claim element prevents the amendment from giving rise to prosecution history estoppel. Our answer to En Banc Question 2, which holds that voluntary amendments are treated the same as other amendments, compels us to reject this argument.

Festo has thus failed to meet its burden under Warner-Jenkinson of establishing a reason unrelated to patentability for the amendment that added the magnetizable

sleeve element. The amendment therefore gave rise to prosecution history estoppel. See Warner-Jenkinson, 520 U.S. at 40-41. Because prosecution history estoppel acts as a complete bar to the doctrine of equivalents, application of the doctrine of equivalents is barred as to this claim element.

We turn now to the sealing ring element. SMC argues that the sealing ring claim element was added to distinguish the prior art and, therefore, is not entitled to any range of equivalents. SMC asserts that arguments accompanying the amendment make clear that the amendment was made to distinguish the prior art. SMC contends that a competitor such as itself reasonably would conclude from the prosecution history that Festo surrendered the difference between the originally claimed sealing means and the sealing rings recited in the amended claims. By the same token, SMC argues, Festo disclaimed the difference between the original and amended claims.

Festo's principal argument is that there is no substantial difference between original claim 1 and the amended claim with respect to the sealing ring element. Specifically, Festo argues that the original claim recited the sealing ring element in means-plus-function language, whereas the amended claim recites the structure described in the specification as performing the recited function ("the corresponding structure"). Festo also argues that the claim amendment did not give rise to prosecution history estoppel because it was made to respond to the 35 U.S.C. § 112 rejection, not to avoid the prior art. Festo contends that the statements accompanying the amendment do not evidence a clear and unmistakable surrender of subject matter and, therefore, did not give rise to prosecution history estoppel.

The sealing ring element was added to claim 1 when the original independent claim 1 was replaced with the independent claim that issued as claim 1. This amendment narrowed the literal scope of the claim because it substituted an independent claim that recited a sealing ring element for an independent claim that did not recite such an element. Even if the amendment that added the sealing ring element merely replaced the means-plus-function language with a recitation of the corresponding structure, the amendment had the effect of narrowing the scope of the claim. A claim element recited in means-plus-function language literally encompasses the corresponding structure and its equivalents. Laitram Corp. v. Rexnord Inc., 939 F.2d 1533, 1536, 19 USPQ2d 1367, 1370 (Fed. Cir. 1991). In contrast, a claim element that recites the corresponding structure does not literally encompass equivalents of that structure. Id. Thus, a claim amendment that replaces means-plus-function language with language reciting the corresponding structure narrows the literal scope of the claim.

We conclude that Festo has not established that the amendment that added the sealing ring element was made for a reason unrelated to patentability. Festo argues that the amendment was made to respond to the 35 U.S.C. § 112 rejection. Because a claim will not issue unless it satisfies the requirements of section 112, an amendment made to satisfy the statute is an amendment made for a reason related to patentability. See supra Answer to En Banc Question 1. The amendment also appears to have been made to distinguish the prior art. Submitted with the amendment was a statement to the effect that German Patent No. 27,37,924 and German Patent No. 19,82,379 “are obviously clearly distinguishable over the subject matter of the claims now present in

th[e] application,” i.e., the amended claims. Also submitted with the amendment was an assertion that “[i]t is clear that neither of these two references discloses the use of structure preventing the interference by impurities located inside the tube and on the outside of the tube while the arrangement is moved along the tube.” In view of these statements, we conclude that the amendment adding the sealing ring element was made to distinguish the German patents and, therefore, was made for a reason related to patentability. See Warner-Jenkinson, 520 U.S. at 30-31 (noting that amendments made to avoid the prior art have been held to give rise to prosecution history estoppel). Thus, Festo cannot establish that the amendment was made for a reason unrelated to patentability. The amendment therefore gave rise to prosecution history estoppel and, in accordance with our Answer to En Banc Question 3, no range of equivalents is available for the sealing ring element.

The jury’s finding of infringement was based on an application of the doctrine of equivalents to the magnetizable sleeve and sealing ring claim elements; accordingly, we must reverse the judgment that claim 1 of the Stoll patent was infringed under the doctrine of equivalents.

3. The district court granted Festo’s motion for summary judgment of infringement under the doctrine of equivalents with respect to independent claim 9 and dependent claims 5 and 6 of the Carroll patent. Festo I (Order), slip op. at 15. The element in all three claims found to be infringed by equivalents is “a pair of resilient sealing rings situated near opposite axial ends of the central mounting member” (a “pair

of sealing rings”).<sup>7</sup> *Id.* at 14. This element was added to claim 9 during reexamination of the Carroll patent. Following the methodology outlined above, we conclude that prosecution history estoppel bars the application of the doctrine of equivalents to this element of the claims of the Carroll patent. In view of this determination, we do not reach the “all elements” rule.

SMC argues that Festo’s purpose for this amendment is not clear.<sup>8</sup> SMC states that because Festo specifically canceled original claim 1, which did not recite a sealing ring at each end of the piston, and added claim 9, which does recite a sealing ring at each end of the piston, the only reasonable conclusion is that the amendment was made for a purpose related to patentability. SMC further asserts that because claim 9 is a combination claim, its patentability hinges on the novelty of the recited combination, including the recited pair of sealing rings. SMC also argues that if the purpose for the amendment is unclear, the Warner-Jenkinson presumption applies, and application of the doctrine of equivalents is barred.

Festo responds by arguing that the amendment adding the pair of sealing rings element was not required, and thus was voluntary. Festo states that because the amendment was voluntary, it cannot give rise to prosecution history estoppel under

---

<sup>7</sup> This element is expressly recited in claim 9, and is included in claims 5 and 6, which depend from claim 9 and which incorporate all of the limitations of that claim, see 35 U.S.C. § 112, ¶ 4 (1994); 37 C.F.R. § 1.75(c) (1999).

<sup>8</sup> SMC did not argue prosecution history estoppel with respect to the Carroll patent before the district court. But upon a GVR from the Supreme Court, a court of appeals may “consider relevant decisions and arguments that were not previously before it” to promote fairness. Stutson v. United States, 516 U.S. 193, 197 (1996). Our consideration of prosecution history estoppel here is particularly appropriate, because Warner-Jenkinson, the case which the Supreme Court asked us to consider in this GVR, specifically addressed the role of prosecution history estoppel as a limitation on the doctrine of equivalents. See Warner-Jenkinson, 520 U.S. at 40.

Warner-Jenkinson. Festo also states that the amendment could not have been required to distinguish the German patent that prompted the reexamination, because the German patent discloses a piston with sealing rings. Festo argues that because the amendment was not made for a purpose related to patentability, the amendment did not create prosecution history estoppel.

To determine whether this claim amendment gave rise to prosecution history estoppel, we first must determine whether the amendment narrowed the literal scope of the claim. As with the elements of the Stoll patent discussed above, the claim element at issue in the Carroll patent was introduced through a new claim, instead of through the amendment of a pending claim. Specifically, during reexamination, independent claim 1, which did not recite a pair of sealing rings, was replaced by independent claim 9, which does recite a pair of sealing rings. This amendment narrowed the literal scope of the claims of the Carroll patent.<sup>9</sup> Accordingly, we must consider the reasons for the amendment.

As discussed above, under Warner-Jenkinson, Festo bears the burden of establishing that the amendment was made for a reason unrelated to patentability. Warner-Jenkinson, 520 U.S. at 40-41. It has failed to do so. Festo admits that there is “[n]o specific mention of the sealing rings” in the prosecution history record. En Banc Responsive Brief of Plaintiff-Appellee Festo Corp., at 49. Moreover, in view of our answer to En Banc Question 2, the voluntary nature of the amendment is irrelevant to the inquiry.

---

<sup>9</sup> Because claims 5 and 6 are dependent claims, any amendment that narrows the scope of the claim from which they depend also narrows claims 5 and 6. See supra note 7.

The prosecution history of the Carroll patent reveals that the amendment that added the pair of sealing rings claim element was motivated by at least one reason related to patentability: a desire to avoid the prior art. In the remarks accompanying the amendment that introduced claim 9, which recites the pair of sealing rings, Carroll stated that the amendment defined the “features of the patentee’s invention that distinguish over the art of record, including” the German patent cited in the request for reexamination. Thus, although the German patent disclosed a piston with sealing rings, Carroll did argue that the combination of features recited in the claims, which includes the pair of sealing rings, distinguished the claims over the German patent. Moreover, when the examiner allowed the reexamined claims, he stated that “the prior art does not teach or render obvious the claimed combination which includes the plurality of magnets, end members, and cushion members in the claimed relationship.” (Emphasis added.) Although the examiner did not specifically reference the pair of sealing rings in his statement of reasons for allowance, his statement emphasizes that it is the claimed combination of elements that was found to be patentable. In view of this prosecution history, Festo cannot establish that the amendment that added the pair of sealing rings element was made for a reason unrelated to patentability. Indeed, the prosecution history indicates that the amendment was made for a reason related to patentability. In accordance with our answer to En Banc Question 3, prosecution history estoppel bars application of the doctrine of equivalents to the pair of sealing rings element. Accordingly, we must reverse the judgment that claims 5, 6, and 9 of the Carroll patent were infringed under the doctrine of equivalents.

## CONCLUSION

The claim elements of the Stoll and Carroll patents that were found to be infringed by equivalents were added to the pertinent claims during prosecution of the Stoll patent and during reexamination of the Carroll patent through amendments that narrowed the scope of the claims. As explained above, Festo has not established explanations for these amendments unrelated to patentability. The amendments therefore gave rise to prosecution history estoppel. Under these circumstances, the amended claim elements are entitled to no range of equivalents. Thus, they cannot be infringed by equivalents. The court's judgment of infringement under the doctrine of equivalents of both the Stoll and Carroll patent is therefore

REVERSED.

COSTS

Each party shall bear its own costs.

# United States Court of Appeals for the Federal Circuit

95-1066

FESTO CORPORATION,

Plaintiff-Appellee,

v.

SHOKETSU KINZOKU KOGYO KABUSHIKI CO., LTD., a/k/a SMC CORPORATION,  
and SMC PNEUMATICS, INC.,

Defendants-Appellants.

PLAGER, Circuit Judge, concurring.

I concur in and join the opinion and judgment of the court. It is a second-best solution to an unsatisfactory situation. Under our preexisting law, a count for infringement under the doctrine of equivalents became a routine part of a patent infringement suit. The game was to convince the trier of fact, typically a jury, that even if an accused product<sup>10</sup> does not infringe the claims as written, the claimed invention and the accused product have only “insubstantial differences,” a wonderfully indeterminate phrase, lending itself to making every decision under the doctrine an individualistic choice, if not simply a flip of the coin. For the rationale behind the “insubstantial differences” rubric, see Hilton Davis Chemical Co. v. Warner-Jenkinson Co., 62 F.3d 1512, 1516-18, 35 USPQ2d 1641, 1644-45 (Fed. Cir. 1995), rev'd and remanded, 520 U.S. 17, 41 USPQ2d 1865 (1997).

---

<sup>10</sup> I use the broad term “product” to include any process, device, etc.

In an attempt to make the phrase “insubstantial differences” less indeterminate, we have continued to resort to the old “function-way-result” formulation, indicating that in appropriate cases—whatever that might mean—the answer could be found through those lenses. See, e.g., Hill-Rom Co. v. Kinetic Concepts, Inc., 209 F.3d 1337, 1343, 54 USPQ2d 1437, 1442 (Fed. Cir. 2000); Kraft Foods, Inc. v. Int’l Trading Co., 203 F.3d 1362, 1371, 53 USPQ2d 1814, 1820-21 (Fed. Cir. 2000); Overhead Door Corp. v. Chamberlain Group, Inc., 194 F.3d 1261, 1270, 52 USPQ2d 1321, 1327 (Fed. Cir. 1999); Augustine Medical, Inc. v. Gaymar Indus., Inc., 181 F.3d 1291, 1304, 50 USPQ2d 1900, 1909 (Fed. Cir. 1999); Vehicular Tech. Corp. v. Titan Wheel Int’l, Inc., 141 F.3d 1084, 1089-90, 46 USPQ2d 1257, 1261 (Fed. Cir. 1998); Dawn Equip. Co. v. Kentucky Farms Inc., 140 F.3d 1009, 1015-16, 46 USPQ2d 1109, 1113 (Fed. Cir. 1998). Though “function” and “result” are in many cases reasonably straightforward, the “way” of an accused product compared to that of the claimed invention has proved to be no more precise a criterion in its application than “insubstantial differences,” for which it was supposed to be a useful surrogate. See, e.g., Overhead Door, 194 F.3d at 1270, 52 USPQ2d at 1327.

Worse yet, whether the trier of fact was judge or jury, the decision about infringement under the doctrine of equivalents does not end with the trial. Given the indeterminate nature of the test, it is not difficult for the losing party to make a plausible argument on appeal that there was “clear error” or that “no reasonable jury could have thought such a thing,” as the case may be. Given the indeterminate nature of the test, this court has shown little reluctance to review these decisions. See, e.g., Hill-Rom, 209 F.3d at 1343, 54 USPQ2d at 1442; Dawn Equip., 14 F.3d at 1015-17, 46 USPQ2d

at 1113-15. The net effect has been that all too often there is no way to know whether a particular product infringes under the doctrine until a panel of this court says so; the rule of analysis gives little real guidance, and equally little predictability.

In today's rulings the court attempts to limit some of the indeterminacy of the doctrine with a set of bright-line rules, trading off areas of uncertainty for a degree of rigidity. Unfortunately, this attempt at injecting certainty into the doctrine contains the potential for unintended consequences, consequences that may do nothing but exacerbate the problem.

What will be the response of the patent bar to the new rules? Past practice has been to claim broadly in the initial application for a patent, and then negotiate with the United States Patent and Trademark Office through one or more rejections until arriving at a mutually acceptable set of claims. Under the new rules of engagement, that process will create full prosecution history estoppel regarding every limitation that is amended for patentability purposes, a term now broadly defined.

Patent counsels may decide that past practice gives up too much under the new rules, and instead may start claiming narrowly with the hope of avoiding rejections and consequent amendments. Literal infringement will become harder to prove because claims will be drafted more narrowly and with greater specificity. That itself may be to the good, since much of current patent litigation involves claim construction issues resulting from the vague, sometimes almost incomprehensible, manner in which claims have been drafted.

An unintended consequence, however, may be that patent litigation will lean ever more heavily on the doctrine of equivalents, especially in those cases in which the

patent application, containing narrowly drawn claims, was approved without any amendment in the area that affects the accused product. The patentee may have little choice but to insist on enforcement under the doctrine of equivalents, if the patent is to be enforced at all. Since today's decision does not change the basic rule of analysis for infringement claims under the doctrine of equivalents, the outcome in those cases will continue to be tested under the pre-existing "insubstantial differences" and its surrogate "function-way-result," with all the game-playing those indeterminate phrases provide.

In time then, the supposed benefits of the doctrinal improvements contained in today's decision may prove illusory.

That is why I consider it a second-best solution. A better solution would be to declare the doctrine of equivalents—a judge-made rule in the first place—to have its roots firmly in equity, and to acknowledge that when and in what circumstances it applies is a question of equitable law, a question for which judges bear responsibility. We have admitted to these roots in a number of cases. See Texas Instruments Inc. v. USITC, 988 F.2d 1165, 1173, 26 USPQ2d 1018, 1024 (Fed. Cir. 1993) ("the doctrine of equivalents has been 'judicially devised to do *equity*'" (quoting Loctite Corp. v. Ultraseal, Ltd., 781 F.2d 861, 870, 228 USPQ 90, 96 (Fed. Cir. 1985)) (emphasis added)); Valmont Indus., Inc. v. Reinke Mfg. Co., 983 F.2d 1039, 1043 n.1, 25 USPQ2d 1451, 1454 n.1 (Fed. Cir. 1993) ("the doctrine 'is designed to do *equity*'" (quoting Perkin-Elmer Corp. v. Westinghouse Elec. Corp., 822 F.2d 1528, 1532, 3 USPQ2d 1321, 1324 (Fed. Cir. 1987)) (emphasis added)); Charles Greiner & Co. v. Mari-Med Mfg., Inc., 962 F.2d 1031, 1036, 22 USPQ2d 1526, 1529 (Fed. Cir. 1992) ("careful confinement of the doctrine of equivalents to its proper *equitable role* . . . promotes certainty and clarity in

determining the scope of patent rights” (emphasis added)); London v. Carson Pirie Scott & Co., 946 F.2d 1534, 1538, 20 USPQ2d 1456, 1458 (Fed. Cir. 1991) (“this *equitable doctrine* evolved from a balancing of competing policies” (emphasis added)).

Were this court to openly acknowledge that the doctrine of equivalents can only be legitimated by its equitable roots and should be treated as an equitable doctrine, important consequences would flow. Trial courts, sitting as courts of equity, would be responsible for deciding whether the doctrine of equivalents should be applied, not unlike the practice regarding the doctrine of inequitable conduct. On appeal to this court, we would review a trial court’s determination under the deferential standard of abuse of discretion.

The test the trial courts would apply would be crafted to blend both objective and subjective factors. The differences between the claimed invention and the accused product would necessarily remain of relevance; and in addition, traditional equitable considerations would focus on matters such as the conduct of the accused product’s sponsors, specifically, the considerations pronounced in the Supreme Court’s seminal opinion in Graver Tank & Manufacturing Co. v. Linde Air Products Co., 339 U.S. 605, 607-08, 85 USPQ 328, 330 (1961):

[C]ourts have also recognized that to permit imitation of a patented invention which does not copy every literal detail would be to convert the protection of the patent grant into a hollow and useless thing. Such a limitation would leave room for—indeed encourage—the unscrupulous copyist to make unimportant and insubstantial changes and substitutions in the patent which, though adding nothing, would be enough to take the copied matter outside the claim, and hence outside the reach of law. . . .

. . . The essence of the doctrine [of equivalents] is that one may not practice a fraud on a patent. Originating almost a century ago in the case of Winans v. Denmead, 15 How. 330, 14 L.Ed. 717, it has been consistently applied by this Court and the lower federal courts, and

continues today ready and available for utilization when the proper circumstances for its application arise.

It is true that “fraud” and “unscrupulous” conduct are not terms of precision, yet they are terms with which judges are familiar. More importantly, they point to the underlying reason for the doctrine; as the Court said, the essence of the doctrine is fraud. Notions of fairness and equity are concerns which over the centuries have permitted courts to reach beyond the fixed scope of legal rights in “proper circumstances,” to use the Court’s phrase. What those circumstances are in regard to patent rights this court over time could determine, and in time develop a refined body of law that emphasizes the exceptional nature of relief under the doctrine. In time, there would be a set of known factors that could be applied predictably, thus giving a degree of decisional certainty to the doctrine, all the while retaining flexibility in the process to deal with new situations—the hallmark of equitable adjudication.

By contrast, the notion of “insubstantial differences” between a particular claim and a particular product, viewed as the governing principle, can never be anything other than an *ad hoc* judgment, dependent on the eye of the beholder in the individual case. Though we talk about considering factors such as the role of copying, interchangeability of elements, and so on, the reality is that, as our cases since Hilton Davis demonstrate, the decision on equivalents remains essentially a subjective call, with repetition of verbal formulae but without transferability from case to case of practical guidance. This to me is the antithesis of the rule of law.

I have previously written at length on this problem and on my suggested approach to its management, see Hilton Davis, 62 F.3d at 1536, 35 USPQ2d at 1661 (Plager, J., dissenting, joined by Archer, C.J., and Rich and Lourie, JJ.), and will not

repeat all that was said there. In this court's earlier attempt to address the difficulties in our equivalents doctrine, see Hilton Davis, 62 F.3d 1512, 35 USPQ2d 1641, passim, the court majority elevated the notion of insubstantial differences to the controlling criterion, on the expressed belief that it had some abstract objectivity. Experience has now shown that belief to have been more hope than reality. In focusing on the mechanistic idea of insubstantial differences, the court failed to grapple with the basic problem of uncertainty in the law. Thus, five short years later, we are again grappling with the problem. This is a self-inflicted wound.

It would be easy now to blame the Supreme Court for the mess we are in, since the Court, in response to our Hilton Davis decision, has opined on the matter. See Warner-Jenkinson Co. v. Hilton Davis Chem. Co., 520 U.S. 17, 41 USPQ2d 1865 (1997). However, I do not believe that the Supreme Court wishes to stand in the way of a sensible solution. For one, the Court expressly declined to consider whether the application of the doctrine of equivalents is a task for the judge or jury. Warner-Jenkinson, 520 U.S. at 38-39, 41 USPQ2d at 1875. That infringement under the doctrine is a fact issue is of no moment; equity courts deal with facts all the time. In addition, a Supreme Court that did not balk at making the most critical aspect of infringement law—claim construction—a matter for judges alone, see Markman v. Westview Instruments, Inc., 517 U.S. 370, 38 USPQ2d 1461 (1996), may, when pressed, find it appropriate to acknowledge the equitable nature of the doctrine of equivalents and the reasons why judges have a comparative advantage in equitable adjudication.

The Supreme Court in its Warner-Jenkinson opinion did opine that “intent plays no role in the application of the doctrine of equivalents.” Warner-Jenkinson, 520 at 36, 41 USPQ2d at 1874. That suggests that at least some of the considerations involved in traditional equitable analysis would not be appropriate. However, the Court’s statement in that regard was preceded by a reference to Graver Tank and the fact that, while Graver Tank leaves room for the inclusion of intent-based elements in the doctrine, it did not *require* them. From this, the Court opined that the “better view” was to exclude intent-based considerations. Today, the Court might well conclude that, since the so-called “objective” approach has proven unworkable, a return to the equitable analysis approach would be the “better view.” Particularly would this be so if this court led the way, since in its Warner-Jenkinson decision the Supreme Court was doing little more than echoing what we had said on the subject of intent in our Hilton Davis opinion.

We are the court primarily responsible for the state of patent law, and the Supreme Court has pronounced it our duty to “best implement procedural improvements to promote certainty, consistency, and reviewability to this area of the law.” Warner-Jenkinson, 520 U.S. at 39 n.8, 41 USPQ2d at 1876 n.8. It is time for us to ‘think outside the box,’ and restore the doctrine of equivalents to its original equitable function and purpose, thus providing a judicial process that lends itself to making the doctrine both determinate and predictable.

Those who are wedded to the existing regimen can no doubt find all sorts of objections to this proposed approach. I cannot say that the approach I advocate is a panacea for all that ails the equivalents practice. I can say that what we have does not work very well, and, as we did in Markman, it is time to try something else, something

that has substantial jurisprudential legitimacy and holds out some promise for improvement. Until such time as this court is of a mind to seek and design a long-term solution to the equivalents problem, however, I have little choice but to join in even this limited effort to cabin what is otherwise, and I fear remains, a doctrine short on predictable results, and short on the achievement of equity to which it owes its existence.

# United States Court of Appeals for the Federal Circuit

95-1066

FESTO CORPORATION,

Plaintiff-Appellee,

v.

SHOKETSU KINZOKU KOGYO KABUSHIKI CO., LTD., a/k/a SMC CORPORATION,  
and SMC PNEUMATICS, INC.

Defendant-Appellants.

LOURIE, Circuit Judge, concurring.

I fully join the majority opinion. However, I write separately to respond to comments and concerns of supporters of the flexible bar rule.

It has been stated by a dissenter that most of the members of the majority have authored opinions supporting a flexible bar. I am one of them. My obligation is to follow precedent, and it is correct that our court has had precedent for a flexible bar, albeit not necessarily consistent precedent. I therefore followed what seemed to be the strongest line of precedent at that time. See, e.g., Sextant, 172 F.3d 817, 49 USPQ2d 1865; Pharmacia & UpJohn Co. v. Mylan Pharms., Inc., 170 F.3d 1373, 50 USPQ2d 1033 (Fed Cir. 1999); Bai v. L&L Wings, Inc., 160 F.3d 1350, 48 USPQ2d 1674 (Fed. Cir. 1998); Laitram Corp. v. Morehouse Indus., Inc., 143 F.3d 1456, 46 USPQ2d 1609 (Fed. Cir. 1998); Lockwood v. Am. Airlines, Inc., 107 F.3d 1565, 41 USPQ2d 1961 (Fed. Cir. 1997). However, in light of experience, and recognizing the Congressional requirement for precision in claims, 35 U.S.C. § 112, ¶2, I am persuaded that when we

have the opportunity en banc to depart from an unworkable rule by holding patent applicants to their actions in the PTO, we should do so. Adoption of a firmer rule today is in the best interest of the patent system.

Our holding does not violate the Supreme Court's guidance in Warner-Jenkinson Co. v. Hilton Davis Chem. Co., 520 U.S. 17 (1997). The key issue decided by the Court in Warner-Jenkinson relating to prosecution history estoppel was whether the reasons for a claim amendment are relevant in determining whether prosecution history estoppel should be applied. Id. at 30. The Court held that the reason for an amendment is relevant, as amendments made for substantial reasons relating to patentability lead to an estoppel. While the Court referred to the avoidance of prior art as a principal reason for an amendment relating to patentability, it did not limit the application of prosecution history estoppel to claims that were amended for prior art reasons. Id. at 30-31. Hence, this court, in its present decision, has refined the scope of "a substantial reason related to patentability" to include any reason relating to a statutory requirement for patentability. In other words, if a claim was not allowable for statutory reasons without an amendment, then the amendment was presumptively made for a reason relating to patentability. Such an amendment may relate either to prior art or to various requirements under 35 U.S.C. §§ 101 and 112.

The Supreme Court has not addressed what scope of equivalents remains when a claim has been clearly amended for patentability reasons. The closest the Court came to doing so was in Warner-Jenkinson, where it created the presumption that an amendment was made for a reason relating to patentability when it is unclear why that amendment was made. The Court then stated: "In those circumstances, prosecution

history estoppel would bar the application of the doctrine of equivalents as to that element.” Warner-Jenkinson, 520 U.S. at 33; see Sextant Avionique, S.A. v. Analog Devices, Inc., 172 F.3d 817, 831, 49 USPQ2d 1865, 1874-75 (Fed. Cir. 1999) (explaining that this language only applies when the reason for an amendment is unknown). It did not otherwise render any holding concerning the scope of equivalents that remains when a claim has clearly been amended for patentability reasons. Thus, this en banc court is free to do so today. In fact, today we merely extend the Supreme Court’s complete bar against the application of the doctrine of equivalents, which applies when it is unclear why an amendment was made and the patentee fails to rebut the presumption that an amendment was made for reasons relating to patentability, to cases in which the patentee clearly amended a claim for patentability reasons.

It has been said that there is no hard evidence showing that the so-called “flexible” bar impairs predictability. While it is true that empirical data may not be available, powerful evidence may be garnered from the experience of this court, which monthly reviews appeals in which infringement is asserted under the doctrine of equivalents even though the accused product is clearly not within the literal scope of the asserted claims. Many of these appeals involve prosecution histories in which amendments for patentability reasons have been made. Yet, equivalence is argued in the hope that one panel might find equivalence where another would not. That surely is persuasive evidence that the current flexible bar is not working. Our court was created with the opportunity and mandate to observe such problems in the law and to act upon a possible solution. See Warner-Jenkinson, 520 U.S. at 39 n.8, 40, 41 USPQ2d at 1875 n.8, 1876 (“We expect that the Federal Circuit will refine the formulation of the test

for equivalence in the orderly course of case-by-case determinations, and we leave such refinement to that court's sound judgment in this area of its special expertise.”). That is why we have been given exclusive jurisdiction over patent appeals. 28 U.S.C. § 1295(a).

It has been suggested that there are settled expectations in the bar and innovation community regarding the present rule. The only settled expectation currently existing is the expectation that clever attorneys can argue infringement outside the scope of the claims all the way through this court of appeals. Such a settled expectation should become unsettled. Surely, when prosecuting a patent, patent practitioners have no settled expectations of being able to assert the doctrine of equivalents. Any patent attorney who fails to claim all that his inventor has invented, and that is patentable, is ill-advised to settle for a narrower claim than he considers justified on the assumption that he can rely on the doctrine of equivalents for broader coverage. Such reliance is a highly risky prospect given that the patent statute requires precise claims. 35 U.S.C. § 112, ¶2. When a patent applicant is faced with a rejection, or expects a rejection, he (or she) is master of his claims. He can stand his ground and appeal, or amend the claims. If the latter course of action is chosen, such conduct, which is known to the world, should bind the applicant. The fact that the applicant may have to appeal an unjustified rejection, incurring loss of time and expense, does not mean that we should refrain from adding clarity to the meaning of claims by holding patent applicants to their actions in the Patent and Trademark Office (“PTO”).

Additionally, the PTO does not make “basic assumptions” relating to a range of equivalents to be allowed. See Warner-Jenkinson, 520 U.S. at 32, 41 USPQ2d at 1872

("[I]f the PTO has been requesting changes in claim language without the intent to limit equivalents . . . we should be extremely reluctant to upset the basic assumptions of the PTO without substantial reason for doing so."). The PTO examines claims in light of the disclosure of the patent application and against the prior art. See 35 U.S.C. § 131 (1994) ("Examination of application"); Manual of Patent Examining Procedure §§ 701, 702 (7th ed. 2000) ("The main conditions precedent to the grant of a patent to an applicant are set forth in 35 U.S.C. [§§] 101, 102 and 103. . . . [T]he examiner should review the contents of [a new] application to determine if the application meets the requirements of 35 U.S.C. [§] 111(a) [(setting forth the basic requirements for a patent application)]."). It does not issue patents with any expectations regarding equivalents.

It is said that stare decisis compels us to stay the course with the old rule. I thought the same regarding Zurko. See Dickinson v. Zurko, 527 U.S. 150, 170-72 (Rehnquist, C.J., dissenting). However, the Supreme Court, in its wisdom, believed that decades of practice should be overturned in order to bring our standard of judicial review of findings of fact made by the PTO into line with the standard of review applied to other agency decisions. Id. at 152. Similarly, a majority of this court believes that important policy considerations relating to achieving the certainty contemplated by Congress justifies departing from an older unworkable rule.

Finally, one of the dissenters fears that today's ruling provides would-be copiers with a free pass to appropriate the essence of an invention and yet escape infringement. That is theoretically true. In the future, a competitor may more closely approach the limits of the claims in a patent in which a narrowing amendment has been made without fear of liability. Occasional injustices may occur. However, I believe that

such occasional injustices will be greatly outnumbered by competitors who will be able to introduce innovative products outside the scope of claims without fear of unjustified, protracted, and expensive litigation. In today's world, the specter of unpredictable equivalence claims haunts too many business decisions, while the overwhelming majority of equivalence claims ultimately fail. It is more than justified to lessen this fear and hold patent applicants to the consequences of their public prosecution decisions. The rule we announce today should encourage innovation, lessen uncertainty, and diminish the volume of unnecessary litigation, while providing patentees with protection commensurate with the disclosed and allowed scope of their inventions.

As for the biotechnology example hypothesized by one of the dissenters, I believe the concern is largely theoretical. The first inventors in a field are only entitled to claim what they can describe and enable, and I am confident that competent patent attorneys can readily craft their claims to cover that subject matter so that estoppel can be avoided. Moreover, subsequent inventors will be better able to find and develop improved products without fear of lawsuits. Predictability will be enhanced.

The fact is that, even under our past rule of flexible bar, no court has rendered a decision holding infringement only under the doctrine of equivalents by an accused gene or protein. To the extent that a competitor has been deterred from developing a new compound for fear that it will be held to be an infringer under an equivalence theory, I believe that our new rule will provide a clear net gain for innovation and the public. They will benefit from the greater certainty that new compounds not within the scope of granted claims can be developed without fear of protracted litigation.

For these reasons, and for others aptly expressed by the majority opinion, I join the majority opinion.

# United States Court of Appeals for the Federal Circuit

95-1066

FESTO CORPORATION,

Plaintiff-Appellee,

v.

SHOKETSU KINZOKU KOGYO KABUSHIKI CO., LTD., a/k/a SMC CORPORATION,  
and SMC PNEUMATICS, INC.,

Defendants-Appellants.

MICHEL, Circuit Judge, concurring-in-part, dissenting-in-part, with whom Circuit Judge RADER joins.

I join the majority opinion with respect to the disposition of Questions 1, 2, 4, and 5. However, I must dissent from the majority's response to Question 3 because I believe it contradicts Supreme Court precedent and policy.

In Warner-Jenkinson Co., Inc. v. Hilton Davis Chemical Co., 520 U.S. 17, 40, 117 S.Ct. 1040, 1054 (1996), the Supreme Court encouraged our court to "refine the formulation of the test for equivalence." I am convinced, however, that the majority's new "complete bar rule," far from being merely such a refinement, contravenes consistent Supreme Court authority. Not only does the majority's new rule directly contradict one Supreme Court holding, but it undermines the legal standard that the Supreme Court has consistently articulated in seven other cases for determining the scope of such estoppel. Moreover, because most patents contain claims that were amended during prosecution, the majority's holding effectively strips most patentees of their rights to assert infringement under the doctrine of equivalents, despite the

Supreme Court's unanimous adherence to the doctrine in Warner-Jenkinson. The majority's new rule constitutes a rejection of the policy advanced by the Supreme Court in Warner-Jenkinson that the all-elements rule and prosecution history estoppel are sufficient to balance the competing needs of granting meaningful protection to patentees and of notifying the public of the effective scope of a patentee's claims.

**I. The Majority's Rule Upsets the Balance Struck by the Supreme Court Through Warner-Jenkinson Between the Competing Needs for Meaningful Patent Protection and Adequate Public Notice.**

Before discussing particular Supreme Court cases, I believe it is important to summarize the doctrinal framework that the Supreme Court has consistently employed for over a century to balance a patentee's need for meaningful protection against copying and the public's need for notice as to the effective scope of a patentee's claims. The Supreme Court has consistently stated, and has done so as recently as Warner-Jenkinson, that application of the all-elements rule, as supplemented by prosecution history estoppel, sufficiently balances the competing needs of meaningful patent protection and adequate public notice. Today's majority upsets this balance, holding that the public notice function of patents can only be fulfilled by limiting the effective scope of patents with amended limitations to the literal wording of such limitations.

The limitations of a patent's claims provide an initial measure of the effective scope of the patent, both literally and under the doctrine of equivalents. The all-elements rule provides that every limitation of a claim is material, and that an accused device lacking a corresponding element, or an equivalent thereof, for every limitation cannot infringe the claim, even under the doctrine of equivalents. See Pennwalt Corp.

v. Durand-Wayland, Inc., 833 F.2d 931, 937, 4 USPQ2d 1737, 1741 (Fed. Cir. 1987) (en banc) (holding that a “device that does not satisfy [a claim limitation] at least equivalently does not function in substantially the same way as the claimed invention,” and thus cannot infringe under the doctrine of equivalents). The Supreme Court has recognized for more than a century that the public is entitled to make, use, or sell devices that lack one or more elements corresponding to the limitations of a patent’s claims, or their equivalents. See, e.g., Shepard v. Carrigan, 116 U.S. 593, 597, 6 S.Ct. 493, 495 (1886) (“Where an applicant for a patent to cover a new combination is compelled by the rejection of his application by the patent-office to narrow his claim by the introduction of a new element, he cannot after the issue of the patent broaden his claim by dropping the element which he was compelled to include in order to secure his patent.”).

In Warner-Jenkinson, the Supreme Court reiterated that under the all-elements rule and prosecution history estoppel, the public receives adequate notice as to the enforceable scope of patent claims. See Warner-Jenkinson, 520 U.S. at 29-30, 117 S.Ct. at 1049 (“So long as the doctrine of equivalents does not encroach beyond the limits [of the all-elements rule] just described, or beyond related limits to be discussed infra [prosecution history estoppel], we are confident that the doctrine will not vitiate the central functions of the patent claims themselves.”) (citation omitted). Moreover, the Warner-Jenkinson Court reaffirmed that, although limiting its application, the all-elements rule still accommodates the right of patentees to assert infringement of some equivalents. See id. at 32, 117 S.Ct. at 1050 (quoting Hubbell v. United States, 179 U.S. 77, 82, 21 S.Ct. 24, 26 (1900) (“If it be a claim to a combination, and be restricted

to specified elements, all must be regarded as material, leaving open only the question whether an omitted part is supplied by an equivalent device or instrumentality.") (citation omitted, emphasis added)); Shepard v. Carrigan, 116 U.S. 593, 598 6 S.Ct. 493, 495 (1886) (same); Fay v. Cordesman, 109 U.S. 408, 421, 3 S.Ct. 244-45 (1883) (same). Under the all-elements rule, the claims themselves provide considerable notice to the public as to the effective scope of the patent (i.e., a patentee cannot assert infringement by a device that lacks an equivalent of one or more limitations of the claim, as issued), while preserving for the patentee a scope of protection under the doctrine of equivalents to prevent copying.

When a patent applicant narrows his claims during prosecution by adding a limitation to traverse a prior art rejection, the substance of the communications between the applicant and the examiner may further notify the public as to additional limits on the enforceable scope of the patent claims. Depending on factors such as the breadth of the examiner's rejection, the manner in which the patent applicant amends his claims to overcome the objection, and the nature of the technology at issue, a reasonable competitor might construe the applicant's remarks and amendments to evince a surrender of claim scope greater than the all-elements rule would require. See Hughes Aircraft Co. v. United States, 717 F.2d 1351, 1363, 219 USPQ 473, 481 (Fed. Cir. 1983) ("Depending on the nature and purpose of an amendment, it may have a limiting effect within a spectrum ranging from great to small to zero."). We describe this doctrine as "prosecution history estoppel," precisely because a hypothetical reasonable competitor should be able to rely on the applicant's representations and amendments

as a surrender of subject matter.<sup>11</sup> The doctrine of prosecution history estoppel supplements the all-elements rule by providing a set of rules for notifying the public whether, and to what extent, the scope of protection is even narrower than what the all-elements rule would allow. See Warner-Jenkinson, 520 U.S. at 34, 117 S.Ct. at 1051 (“[P]rosecution history estoppel places reasonable limits on the doctrine of equivalents, and further [than the all-elements rule] insulates the doctrine from any feared conflict with the Patent Act.”).

In contrast to the doctrine of prosecution history estoppel we have applied until today, the majority’s new complete bar rule does not supplement the all-elements rule as a way to further clarify the scope of equivalents available to the patentee. Rather than attempt to “refine” our case law as to how the added claim limitations should be enforced in light of the substance of the communications between examiner and applicant, the majority’s new rule simply forecloses all application of the doctrine of equivalents for any amended claim limitation. This approach by-passes the all-elements rule altogether. See Maj. Op. at 56 (“Following the methodology outlined above, we conclude that prosecution history estoppel bars the application of the doctrine of equivalents to this element of the claims of the Carroll patent. In view of this determination, we do not reach the ‘all elements’ rule.”).

The majority’s concept of prosecution history estoppel is hardly an “estoppel” at all. The majority’s approach gives no consideration to whether a reasonable competitor would rely on the nature of the rejections and of the amendments and statements

---

<sup>11</sup> We do not require the alleged infringer to demonstrate actual personal reliance on the statements in the prosecution history. See 5 Donald S. Chisum, Chisum on Patents, § 18.05[1][a][i], at 18-416.

between the applicant and the examiner as evidence of a surrender of subject matter. According to the majority, once there has been a limiting amendment, no consideration may be given to the breadth of the rejection, the closeness of the prior art, the manner of the applicant's remarks and amendments, or the nature of the technology. All equivalents of that limitation are foreclosed by the mere fact of amendment. The majority's rule might more aptly be called "bar by amendment" rather than "estoppel," which has always been measured by what a reasonable competitor would understand the applicant to have surrendered in order to procure his patent. I believe that looking solely to the fact of amendment, rather than the substance of communications between the applicant and the examiner, is contrary to the principles that the Supreme Court (and our court) has always applied in determining the scope of estoppel.

Under the majority's rule, in contrast to the Supreme Court's application of the all-elements rule and prosecution history estoppel, a patentee retains no range of equivalents for a claim limitation that has been amended for patentability reasons. This approach upsets the Supreme Court's balance between the competing needs of sufficient public notice and meaningful patent protection. At the very minimum, I believe the majority's rule is unfairly harmful, because it deprives patentees of any recourse to the doctrine of equivalents for any added or narrowed limitation, no matter how minor the amendment. More importantly, however, I believe that precluding a patentee's right to seek protection under the doctrine of equivalents for amended limitations will, in many cases, "convert the protection of the patent grant into a hollow and useless thing." Graver Tank & Mfg. Co. v. Linde Air Products Co., 339 U.S. 605, 607, 70 S.Ct. 854, 856 (1950).

Would-be copyists, of course, will exploit the majority's bar. Unwittingly, the majority has severely limited the protection previously available to patentees. Indeed, it may nullify the doctrine of equivalents. Under the majority's approach, anyone who wants to steal a patentee's technology need only review the prosecution history to identify patentability-related amendments, and then make a trivial modification to that part of its product corresponding to an amended claim limitation. All the other limitations may be copied precisely. The competitor will then be free to make, use, or sell an insubstantial variant of the patentee's invention. It appears to me that this complete bar approach upsets the balance that the Supreme Court has struck. Under this approach, most patentees will lose the protection against copying that the Supreme Court unanimously reaffirmed in Warner-Jenkinson.

## **II. Supreme Court Precedent**

The majority asserts that the Supreme Court has never "addressed or answered" the question as to whether a scope of equivalents remains after a claim limitation has been added or amended for a reason relating to patentability. The majority quotes language from six Supreme Court cases dealing with prosecution history estoppel,<sup>12</sup> and asserts that in these six cases, "the Court did not analyze the actual scope of equivalents that might be available when prosecution history estoppel applied." The Court thereby posits that "[w]e think it is fair to say" that this question remains open. I agree with the majority that, in four of these six cases, the Supreme Court did not

---

<sup>12</sup> These six cases are Warner-Jenkinson, 520 U.S. at 17, 117 S.Ct. at 1040; Exhibit Supply Co. v. Ace Patents Corp., 315 U.S. 126, 62 S.Ct. 513 (1942); Smith v. Magic City Kennel Club, 282 U.S. 784, 51 S.Ct. 291 (1931); Weber Elec. Co. v. E.H. Freeman Elec. Co., 256 U.S. 668, 41 S.Ct. 600 (1921); Hubbell v. United

address the question presently at bar. As to the other two cases, Hubbell v. United States, 179 U.S. 77, 21 S.Ct. 24 (1900), and Shepard v. Carrigan, 116 U.S. 593, 6 S.Ct. 493 (1886), the majority and I draw different conclusions. Most importantly, however, I can hardly agree with my colleagues that, upon a review of only these six Supreme Court cases, they can rightfully draw the conclusion that never has the Court “answered or addressed” today’s question.

The Supreme Court has decided many more than these six cases relevant to prosecution history estoppel. Hurlbut v. Schillinger, 130 U.S. 456, 9 S.Ct. 584 (1889), is one particularly noteworthy case, wherein the Supreme Court ruled that a patentee, who had disclaimed a portion of his invention, and who had been found in prior litigation to be precluded from asserting his claims against one accused device in light of that disclaimer, nonetheless remained entitled to a judgment of infringement by a different device that was more closely equivalent to his claimed invention. The majority also disregards the legal standard repeatedly articulated by the Supreme Court that is consistent only with a flexible approach to prosecution history estoppel, i.e., that an amended claim may be infringed if “an omitted part is supplied by an equivalent device or instrumentality.” See, e.g., Warner-Jenkinson, 520 U.S. at 32, 117 S.Ct. at 1050; Fay v. Cordesman, 109 U.S. 408, 420-21, 3 S.Ct. 236, 244-45 (1883). Furthermore, the majority nowhere recognizes that the Supreme Court has articulated a consistent, uniform doctrine for applying the doctrine of prosecution history estoppel since the 1880s, with no suggestion in Warner-Jenkinson or other recent cases that it sought to depart from its earlier holdings.

---

States, 179 U.S. 77, 21 S.Ct. 24 (1900); and Shepard v. Carrigan, 116 U.S. 593, 6

Many of the cases I cite were decided in the 1800s. Before discussing them, I would like to make three general points about this older precedent. First, the Supreme Court was very active in the patent field in the late 1800s. From 1880 to 1900, the Court decided no fewer than ninety patent infringement cases, with many of these cases being highly relevant to the present appeal. From my review of these cases, and the far fewer number of cases the Court decided in the 1900s, it appears that the Court established the basic contours of patent law in the late 1800s, including on equivalency and estoppel, and has reaffirmed these same principles ever since. Indeed, more recent Supreme Court cases, such as Warner-Jenkinson, 520 U.S. at 31, 117 S.Ct. at 1049-50; Graver Tank & Manufacturing Co. v. Linde Air Products Co., 339 U.S. 605, 608-09, 70 S.Ct. 854, 856 (1950); Exhibit Supply Co. v. Ace Patents Corp., 315 U.S. 126, 136, 62 S.Ct. 513, 518-19 (1942); and Smith v. Magic City Kennel Club, Inc., 282 U.S. 784, 790, 51 S.Ct. 291, 293-94 (1931), are remarkable in the degree to which they cite nineteenth century cases, and in their express insistence on adhering to older precedent.

Second, in addition to being old, many of the cases I cite involve reissue patents.<sup>13</sup> But the law of prosecution history estoppel has developed with equal

---

S.Ct. 493 (1886).

<sup>13</sup> The Patent Act of 1836 authorized a patentee to surrender the claims of his original patent and to obtain a reissue patent whenever the patent was “inoperative, or invalid, by reason of a defective or insufficient description or specification, or by reason of the patentee claiming in his specification as his own invention, more than he had or shall have a right to claim as new.” Patent Act of 1836, Ch. 357, 5 Stat. 117, at § 13 (July 4, 1836); see also Gage v. Herring, 107 U.S. 640, 644-45, 2 S.Ct. 819, 823 (1883). The Patent Act of 1870, which governs many of the cases discussed below, made no change in this provision, except for the deletion of the words “description or.” Patent Act of 1870, Ch. 230, 16 Stat. 198-217, at § 53 (July 8, 1870); see also Gage, 107 U.S. at 644-45, 2 S.Ct. at 823.

applicability to reissue patents and original patents whose claims were amended during prosecution. By at least 1879, the Supreme Court recognized that the process of obtaining a reissue patent precluded the patentee from recapturing that which he had disclaimed (i.e., surrendered) through the reissuance process. See Leggett v. Avery, 101 U.S. 256, 260 (1879); see also Union Metallic Cartridge Co. v. United States Cartridge Co., 112 U.S. 624, 642, 5 S.Ct. 475, 485 (1884) (applying principles of prosecution history estoppel to claims of reissue patent). Considering that Leggett, which concerns a reissue patent, is the foundation for much of the Court's subsequent treatment of what we now call "prosecution history estoppel," see, e.g., Schriber-Schroth Co. v. Cleveland Trust Co., 311 U.S. 211, 221, 61 S.Ct. 235, 240 (1940) (citing Leggett as basis of estoppel holding), I find nothing to suggest that the presence of a reissue patent, in several cases cited below, alters the legal standards articulated by the Court for resolving disputes involving prosecution history estoppel on claims issued in the original prosecution. Rather, the Supreme Court compared the original and reissue claims to measure the scope of estoppel, treating the reissue claims like amended claims.

Finally, although these older cases do not specifically recite either of the synonymous phrases "prosecution history estoppel" or "file wrapper estoppel," the principles articulated in these cases form the core of the doctrine of prosecution history estoppel that we have applied until today. The phrase "file wrapper estoppel" was not employed by the Supreme Court until its decision in Exhibit Supply Co. v. Ace Patents Corp., 315 U.S. 126, 128, 62 S.Ct. 513, 515 (1942), and the Supreme Court did not use the phrase "prosecution history estoppel" until Warner-Jenkinson, 520 U.S. at 30, 117

S.Ct. at 1049. Nonetheless, the Court recognized in Warner-Jenkinson that many of the cases I cite below, such as Sutter and Hubbell, indeed set forth the principles of our present doctrine of “prosecution history estoppel.” See Warner-Jenkinson, 520 U.S. at 30-31, 117 S.Ct. at 1049-50. I believe that the absence of the phrase “prosecution history estoppel” in the cases I cite is hardly a convincing basis for distinguishing them.

**A. Goodyear Dental Vulcanite Co. v. Davis**

One of the first cases in which the Supreme Court discussed the principles underlying our present doctrine of prosecution history estoppel is also one of the most instructive. Goodyear Dental Vulcanite Co. v. Davis, 102 U.S. 222, 223-27 (1880) concerns a reissue patent for a rubberized dental plate, claiming “[t]he plate of hard rubber or vulcanite, or its equivalent, for holding artificial teeth, or teeth and gums, substantially as described.” The Supreme Court recognized that the patentee, Cummings, had restricted his claims during the reissuance process to a dental plate made of hard “vulcanized” rubber, and thus that Cummings was precluded from asserting that a dental plate made of celluloid (a softer, chemically distinct, unvulcanized material) was an equivalent of the claimed invention. Notwithstanding this restriction on the available scope of equivalents, the Court nonetheless stated that Cummings could assert infringement by other products that were equivalent to those recited in the patent:

If, when the patent was granted, there were known substances, other than rubber or caoutchouc, gutta-percha, or gums, that could be vulcanized by the Goodyear process, and converted from a soft into a hard, elastic material, any use of that material for a dental plate might have been an equivalent for the Cummings material, and an infringement of his patent.

Id. at 227 (emphasis added). The Court continued, stating that although Cummings had limited his claims to a vulcanized product, and was thus precluded from asserting the equivalence of a softer, celluloid, unvulcanized product, Cummings nonetheless retained protection against equivalents. The Court stated: “It may be conceded the patentee is protected against equivalents for any part of his invention.” Id. at 230 (emphasis added). Thus, the Court recognized that although a patentee, by amending his claims, may be precluded from asserting a large range of equivalents, he may still be able to assert his patent against devices that fall within a narrower range of equivalents. This statement is only consistent with a flexible approach to prosecution history estoppel, and would be meaningless if the Court had intended a complete bar to apply.

Moreover, the Court stated that Cummings was protected against equivalents “whether he had claimed them or not.” Id. By this statement, the Court clarified that it was not necessary for patent applicants like Cummings to recite the words “or its equivalent” or “substantially as described” in the patent claims, but rather that patentees’ protection against equivalents arises independently of the particular wording of the claims.

The majority argues that the Goodyear Court “did not discuss prosecution history estoppel.” I agree that the particular phrase “prosecution history estoppel” nowhere appears in Goodyear. However, the principles articulated in Goodyear are the foundation of the modern doctrine of prosecution history estoppel. Indeed, the Supreme Court’s first opinion to discuss the doctrine of “file wrapper estoppel,” Exhibit Supply Co. v. Ace Patents Corp., 315 U.S. 126, 128, 62 S.Ct. 513, 515 (1942),

specifically mentions Goodyear as a basis of that doctrine. It is also true, as the majority points out, that the Goodyear Court did not rule in favor of the patentee, and thus that the language I cite does not constitute a holding. I cannot agree with the majority, however, that the Court's statements fail to constitute "explicit and carefully considered language," and that the rule of Goodyear may be disregarded. Rather, as I will describe in the next case I cite, the Court soon thereafter applied these principles to hold that a patentee retains a range of enforceable equivalents, despite having made a disclaimer that restricted his available range of equivalents.

**B. Hurlbut v. Schillinger**

Hurlbut v. Schillinger, 130 U.S. 456, 9 S.Ct. 584 (1889), and an earlier related case, California Artificial Stone-Paving Co. v. Schalicke, 119 U.S. 401, 7 S.Ct. 391 (1886), concern a patent for an improvement in concrete pavements, claiming an "arrangement of tar-paper or its equivalent between adjoining blocks of concrete," such that the imposition of tar-paper between the paving blocks would facilitate the removal of a block that subsequently becomes damaged, without disrupting adjacent blocks. Schillinger obtained a reissue patent, amending the original specification to state, among other things, that "where cheapness is an object, the tar-paper may be omitted and the blocks formed without interposing anything between their joints." Id. at 462, 9 S.Ct. at 586. In his reissue patent, Schillinger also obtained a claim that omitted any reference to tar-paper or its equivalent.

After obtaining his reissue patent, Schillinger filed a disclaimer with the Patent Office, stating that his reissue claim was too broad, and covered kinds of pavement "of which your petitioner was not the first inventor." Id. at 463, 9 S.Ct. at 586. Schillinger

disclaimed any coverage to an arrangement of pavement wherein the tar-paper is omitted and no material is used to separate the concrete blocks. See id.

Schillinger brought suit against several competitors, and two of the disputes reached the Supreme Court. In the first, California Paving, 119 U.S. at 406-07, 7 S.Ct. at 394-95, the Court remarked that the accused paving was neither separated into individual blocks, and nor had any material been interposed between the blocks while they were still plastic. The Court noted that Schillinger had disclaimed “the forming of blocks from plastic material without interposing anything between their joints while in the process of formation.” Id. at 407, 9 S.Ct. at 394. The Court found no infringement, concluding that “what the defendant did was just what the patentee disclaimed.” Id. at 407, 9 S.Ct. at 395. Thus, it is clear from California Paving that Schillinger’s disclaimer was sufficient to preclude him from asserting infringement by the defendant’s arrangement of pavement. Although the Court did not employ the phrase “prosecution history estoppel” to describe this limitation on the effective scope of his patent, I think it is apparent that Schillinger’s disclaimer had invoked such an estoppel.

In Schillinger’s second suit to reach the Supreme Court, the accused product was an arrangement of pavement whose individual blocks, while still plastic, were separated from one another by means of a trowel. See Hurlbut, 130 U.S. at 467-68, 9 S.Ct. at 588. The Court recognized that the stroke of a trowel to separate the blocks was different than inserting tar-paper between the blocks. See id. The Court also recognized that Schillinger had limited the protective scope of his reissue patent through his disclaimer, and was thus precluded from asserting his claims against pavement arrangements wherein the blocks were not separated. See id. at 466, 9

S.Ct. at 587. The Court nonetheless held that Schillinger was still entitled to a range of equivalents after having made his disclaimer, and that using a trowel to separate the blocks was equivalent to using tar-paper. The Court stated:

The effect of the disclaimer was to leave the patent to be one for a pavement wherein the blocks are formed by interposing some separating material between them. To limit the patent to the permanent interposition of a material equivalent to tar-paper, would limit the actual invention. The use of a bottom layer of coarse cement, and placing it on a course of fine cement, and dividing the upper course into blocks by a trowel run partially or wholly through the upper course while it is plastic, in a line coincident with the joints between the sections in the lower layer, accomplishes the substantial results of Schillinger's invention, in substantially the way devised by him, and is within the patent as it stands after the disclaimer.

Id. at 465, 9 S.Ct. at 587 (emphasis added). The Court continued, emphasizing that the effect of the disclaimer was not to completely preclude Schillinger from asserting equivalence, but rather that the scope of the preclusion was determined by reference to the actual embodiments that Schillinger had surrendered. The Court stated:

The disclaimer took out of the first claim of the reissue only so much thereof as claimed a concrete pavement made of the plastic material laid in detached blocks, without interposing anything in the joints in the process of formation, leaving that claim to be one for such a pavement laid in detached blocks, when free joints are made between the blocks, by interposing permanently or temporarily between them, in the process of their formation, tar-paper or its equivalent.

Id. (emphasis added). The Court concluded that the accused pavement constituted an equivalent of the claimed invention “as it stands after the disclaimer,” and thus that Schillinger was entitled to a judgment of infringement. The Court stated:

We are, therefore, of opinion that the first claim of the reissue, as it stands after the disclaimer, is infringed, because the defendant's pavement is a concrete pavement, laid in detached blocks or sections, substantially in the manner shown and described in the specification of the reissue, the detached blocks in the upper course being the equivalent of the detached blocks or sections of the Schillinger

pavement; and that the second claim of the reissue is infringed, because the temporary use of the trowel or cutting instrument, to divide the upper course into blocks, is the equivalent of the tar-paper of the Schillinger patent . . . .

Id. at 469, 9 S.Ct. at 588 (emphasis added).

Today's majority, noting that Schillinger recited the phrases "substantially" and "or its equivalents" in the patent claims, appears to argue that the defendant in Hurlbut had literally infringed the claims, and that the Court "did not discuss the issue of the scope of equivalents that remained under the doctrine of equivalents after the disclaimer." I do not agree, however, that the mere presence of the words "equivalent" or "substantially" in Schillinger's claim language somehow reduces the infringement analysis to one of literal infringement. As noted above, the Goodyear Court made clear that a patentee is protected against equivalents, "whether he had claimed them or not." Goodyear, 102 U.S. at 230. The tension at the heart of these disputes--between meaningful patent protection and adequate public notice--persists regardless of whether "equivalents" are recited in the claims or are claimed implicitly through the doctrine of equivalents. I believe that the legal framework employed by the Hurlbut Court to limit the range of equivalents available to Schillinger applies whether or not the words "substantially" or "or its equivalents" appear in the claims.

The Court's holding in Hurlbut is simply an application of the principles it established in Goodyear. In both cases, the Court recognized that the patent applicants' disclaimers and amendments had precluded the patentees from asserting the equivalence of certain accused devices. In both cases, however, the Court stated that, despite the disclaimer or amendment, the patentee retained a limited scope of equivalents. Although the Court articulated its reasoning in Goodyear without holding

in favor of the patentee, these same principles are the foundation of the Court's clear holding for the patentee in Hurlbut. As I read these cases, Goodyear and Hurlbut entitle a patentee to a range of equivalents despite the fact of a limiting amendment.

**C. The Majority's Holding Contradicts Six Other Supreme Court Cases That Declare a Flexible Approach to Prosecution History Estoppel.**

Goodyear and Hurlbut are the two cases I have identified where the Court has most fully described its flexible approach to prosecution history estoppel. These cases, however, are far from the only instances where the Court has set forth legal principles that are consistent only with a flexible approach. Following are six more cases where the Court set forth a legal standard that provides that patentees who have amended their original claims, and who are thus precluded from asserting a certain range of equivalents, nonetheless retain the right to assert a more limited range of equivalents. In three of these cases, the Supreme Court declared that a patentee who had introduced a new claim limitation during prosecution or during reissuance would be entitled to enforce his amended claims by showing that in the accused device, "an omitted part is supplied by an equivalent device or instrumentality." Hubbell v. United States, 179 U.S. 77, 82, 21 S.Ct. 24, 26 (1900); Shepard v. Carrigan, 116 U.S. 593, 598, 6 S.Ct. 493, 495 (1886); Fay v. Cordesman, 109 U.S. 408, 420-21, 3 S.Ct. 236, 244-45 (1883). Moreover, the Supreme Court restated this legal standard verbatim in Warner-Jenkinson, 520 U.S. at 32, 117 S.Ct. at 1050 (quoting Hubbell). Although the Supreme Court recited this same legal standard in the very same words on four separate occasions over the span of 113 years, today's majority regards these cases as lacking "explicit and carefully considered language." I cannot agree.

1. **Fay v. Cordesman**

Fay v. Cordesman, 109 U.S. 408, 409, 3 S.Ct. 236, 237 (1883), concerned three patents, including a reissue patent, for a mechanical saw whose blade is alternately pushed and pulled. The reissue patent contained five claims, all of which were substantially amended from the single claim of the original patent. See id. at 413, 3 S.Ct. at 239-40. Noting that the accused device, a continuously rotating band saw, did not embody an adjustable saw guard, as recited in an asserted claim of the reissue patent, the Court ruled that there could be no infringement because: “If it be a claim to a combination, and be restricted to specified elements, all must be regarded as material, leaving open only the question whether an omitted part is supplied by an equivalent device or instrumentality.” Id. at 420-21, 3 S.Ct. at 244-45 (emphasis added). Although Fay does not recite the words “prosecution history estoppel,” its legal standard has been repeatedly reaffirmed by the Supreme Court, through Warner-Jenkinson, as governing the application of prosecution history estoppel. See Warner-Jenkinson, 520 U.S. at 32, 117 S.Ct. at 1050 (quoting Hubbell v. United States, 179 U.S. 77, 82, 21 S.Ct. 24, 26 (1900), which in turn quotes Fay). Fay, as subsequently recognized by Warner-Jenkinson, clearly indicates that, despite having amended his claims through the reissuance process, the inventor would still be able to assert his claims against other devices that were more closely equivalent to his invention. Fay’s legal standard would be meaningless if the Court had intended to disallow equivalents for amended claims.

## **2. Shepard v. Carrigan**

In Shepard v. Carrigan, 116 U.S. 593, 6 S.Ct. 493 (1886), the Court considered whether a skirt protector lacking a “fluted or plaited band or border” infringed a claim that had been amended to include such a limitation. The Court stated that its previous holding in Fay, 109 U.S. at 420-21, 3 S.Ct. at 244-45, was “decisive of the present case,” 116 U.S. at 598, 6 S.Ct. at 495, and thus that the proper inquiry was “whether an omitted part is supplied by an equivalent device or instrumentality.” Id. (quoting Fay, 109 U.S. at 420-21, 3 S.Ct. at 244-45) (emphasis added). Despite ruling that the patentee had “explicitly abandoned” claims to an unplaited skirt protector, the Court’s legal standard clearly contemplates that other skirt protectors could be found to constitute “an equivalent device or instrumentality” of the invention claimed in the reissue patent. Id. Again, the legal standard governing Shepard is repeated, verbatim, in Warner-Jenkinson. See Warner-Jenkinson, 520 U.S. at 32, 117 S.Ct. at 1050. Although the Shepard Court did not use the phrase “prosecution history estoppel” to describe the limit on equivalents it applied, the Supreme Court subsequently interpreted Shepard as invoking such an estoppel. See Exhibit Supply, 315 U.S. at 128, 62 S.Ct. at 515 (citing Shepard as basis of doctrine of file wrapper estoppel).

## **3. Sutter v. Robinson**

In Sutter v. Robinson, 119 U.S. 530, 7 S.Ct. 376 (1886), the patentee claimed an apparatus for “resweating” tobacco. During prosecution, the applicant amended his claims to avoid the prior art, stating that the inventive aspect was the use of a wooden, rather than metal, vessel for the tobacco. The Court stated that “the ultimate question” in the case was “whether, in such an apparatus, the use of the cases, or boxes, or

packages, in which the tobacco leaves are originally packed by the producer is equivalent to the wooden tobacco-holder mentioned in the complainants' specification." Id. at 542, 7 S.Ct. at 382 (emphasis added). Although the Court found that the accused device could not infringe the patent in light of the applicant's amendment, the Court's "ultimate question" clearly contemplates that other devices, although not exact copies of the patented invention, might have infringed the amended aspect of the claim under the doctrine of equivalents. This "ultimate question," of course, would be irrelevant if the Court intended a complete bar to govern equivalency disputes involving amended claims. The Warner-Jenkinson Court cites Sutter as a proper application of the doctrine of prosecution history estoppel. See Warner-Jenkinson, 520 U.S. at 17 n.5, 117 S.Ct. at 1050 n.5 (noting that in Sutter, "estoppel applied where, during patent prosecution, the applicant 'was expressly required to state that [the device's] structural plan was old and not of his invention'").

#### **4. Phoenix Caster Co. v. Spiegel**

Phoenix Caster Co. v. Spiegel, 133 U.S. 360, 10 S.Ct. 409 (1890), concerns claims to a furniture caster. The claims had been repeatedly narrowed during prosecution to a caster containing an elliptical housing opening, a collar, and a rocker-formed collar bearing. The Court ruled that the accused device "is not of a construction similar to" the patented invention, and that the accused device did not contain "any equivalent for such 'rocker-formed collar bearing,'" and thus that there was no infringement. Id. at 369, 10 S.Ct. at 412 (emphasis added). The Court did not foreclose application of the doctrine of equivalents in light of the patentee's multiple narrowing amendments, but still inquired whether the accused device was "similar to" or

an “equivalent for” the claimed invention. Id. Although the majority suggests that Phoenix does not involve prosecution history estoppel, the Supreme Court subsequently cited Phoenix as supporting the proposition at the heart of prosecution history estoppel that “[i]t is a rule of patent construction consistently observed that a claim in a patent as allowed must be read and interpreted with reference to claims that have been cancelled or rejected and the claims allowed cannot by construction be read to cover what was thus eliminated from the patent.” Schriber-Schroth Co. v. Cleveland Trust Co., 311 U.S. 211, 220-21, 61 S.Ct. 235, 239 (1940).

#### **5. Royer v. Coure**

In Royer v. Coure, 146 U.S. 524, 13 S.Ct. 166 (1892), the circuit court held that in light of the patentee’s multiple limiting amendments, his claims were restricted to the eight-step process described in the specification, and that to find an infringement of the process, “a person must be shown to have followed substantially the same process, the same mode of reaching the result as is described in the specifications.” Id. at 530-31, 13 S.Ct. at 169 (quoting Royer v. Manufacturing Co., 20 F. 853, 854, 856 (C. C. Ill. 1884)) (emphasis added). The Supreme Court fully endorsed this approach to limiting the application of the doctrine of equivalents, holding that “[w]e are of opinion that the views set forth by the circuit court are sound, and that the decree must be affirmed.” Id. Royer thus confirms that a patentee with an amended claim may still assert his rights against those utilizing “substantially the same process” as the claimed invention. Id. Although the phrase “prosecution history estoppel” is nowhere found in Royer, the Supreme Court subsequently interpreted Royer as invoking such an estoppel. See Keystone Driller Co. v. Northwest Engineering Corp., 294 U.S. 42, 48, 55 S.Ct. 262,

265 (1935) (citing Royer to argue that “[w]here such broad claims are denied and a narrower substituted, the patentee is estopped to read the granted claim as the equivalent of those which were rejected”).

## **6. Hubbell v. United States**

In Hubbell v. United States, 179 U.S. 77, 21 S.Ct. 24 (1900), the patentee had repeatedly amended his claims to a bullet cartridge. As the majority notes, the Court recognized that these amendments “must be strictly construed against the inventor and in favor of the public, and looked upon in the nature of disclaimers.” Id. at 83-84, 21 S.Ct. at 27. The Court, however, nowhere suggested that these amendments foreclosed the patentee from all protection against equivalents. To the contrary, the Court asked whether the accused device contained the limitation at issue, or, if it did not, “whether [the] omitted part is supplied by an equivalent device or instrumentality.” Id. at 82, 21 S.Ct. at 26 (quoting Fay v. Cordesman, 109 U.S. 408, 3 S.Ct. 236 (1883)) (emphasis added). The Court recognized that, although the claims had been amended, the patentee was still “entitled to a fair construction of the terms of his claim as actually granted.” Id. at 80, 21 S.Ct. at 25. To me, this reference to “fair construction” can only be a reference to the doctrine of equivalents, as the Court recognized that the patentee retained the right to prohibit infringement by “an equivalent device or instrumentality.” As noted above, Hubbell’s legal standard is quoted verbatim in Warner-Jenkinson, 520 U.S. at 32, 117 S.Ct. at 1050.

Although the majority suggests that the Hubbell Court did not “discuss[] prosecution history estoppel,” the Supreme Court has indeed interpreted Hubbell as an application of prosecution history estoppel. See Warner-Jenkinson, 520 U.S. at 31 n.5,

117 S.Ct. at 1050 n.5 (citing Hubbell as holding that “patentee estopped from excluding a claim element where element was added to overcome objections based on lack of novelty over prior patents”). I do not agree with the majority that the absence of the words “prosecution history estoppel” in Hubbell and in the other cases discussed above somehow means that the Supreme Court “did not discuss the issue presented in En Banc Question 3.” Rather, I believe that the Supreme Court has repeatedly set forth a legal standard that preserves the right of patentees to assert equivalents for amended claim limitations.

**D. Warner-Jenkinson Reaffirms Earlier Supreme Court Precedent.**

The Supreme Court’s most recent decision regarding prosecution history estoppel is remarkable for the extent to which it reaffirms earlier precedent and affirmatively supports the application of flexible estoppel. See Warner-Jenkinson, 520 U.S. at 17, 117 S.Ct. at 1040. In analyzing whether prosecution history estoppel precludes a finding that an accused product infringes an amended patent claim under the doctrine of equivalents, the Court said that courts may determine “the reason for” and the “manner” of the amendment. Id. at 33 n.7, 117 S.Ct. at 1051 n.7. Such an analysis would be unnecessary, of course, if the Court intended a complete bar. See 5 Donald S. Chisum, Chisum on Patents, § 18.05[3][c], at 18-509 (“Reference to the ‘manner’ of the amendment hints that a court may indeed consider whether an amendment leaves some room for equivalents of the limitation added.”). The Court assumes that the PTO may have relied “upon a flexible rule of estoppel” when evaluating patent applications, and that if so it would be improper “to upset the basic assumptions of the PTO.” Warner-Jenkinson, 520 U.S. at 32, 117 S.Ct. at 1050. As

Professor Chisum has stated, to read Warner-Jenkinson “as precluding all equivalency for a claim element added by an amendment driven by the prior art [would be] contrary to the Supreme Court’s rejection of a ‘rigid’ estoppel approach.” Donald S. Chisum, The Scope of Protection for Patents After the Supreme Court’s Warner-Jenkinson Decision: The Fair Protection-Certainty Conundrum, 14 Computer & High Tech. L.J. 1, 57 (1998) (emphasis added).

Warner-Jenkinson, however, did establish a special presumption for cases where the prosecution history reveals no reason for a narrowing amendment. In these limited circumstances, the Court held that a presumption applies that the amendment was made for a reason related to patentability, and that if the patentee is later unable to rebut that presumption, a bar to equivalents applies to the claim limitation added by the amendment. See Warner-Jenkinson, 520 U.S. at 33, 117 S.Ct. at 1051. Although the Court’s holding does not explicitly resolve whether a bar would apply outside of the factual circumstances of that case, nothing in the opinion suggests that the Court intended to so limit the doctrine of equivalents.

That the Court’s holding in Warner-Jenkinson is indeed narrow, and not intended to upset the established law of estoppel, is underscored by its extensive reliance on precedent dating back to 1886. In declining the invitation to alter existing rules, the Warner-Jenkinson Court relied on older Supreme Court decisions such as Exhibit Supply Co. v. Ace Patents Corp., 315 U.S. 126, 62 S.Ct. 513 (1942), Keystone Driller Co. v. Northwest Engineering Corp., 294 U.S. 42, 55 S.Ct. 262 (1935), Smith v. Magic City Kennel Club, Inc., 282 U.S. 784, 788, 51 S.Ct. 291, 293 (1931), Computing Scale Co. of America v. Automatic Scale Co., 204 U.S. 609, 618-20 (1907), Hubbell v. United

States, 179 U.S. 77, 83, 21 S.Ct. 24, 26-27 (1900), and Sutter v. Robinson, 119 U.S. 530, 541, 7 S.Ct. 376, 381-82 (1886). The Court's reliance on its earlier cases and its description of the methodology adopted in each of those cases indicate that the Warner-Jenkinson Court did not intend to overrule or change this well-established precedent; indeed, by citing to these cases, the Warner-Jenkinson Court endorsed their approach. Further, many of the cases cited in Warner-Jenkinson themselves rely on the cases I discuss above which, I believe, declare a flexible bar. See, e.g., Hubbell, 179 U.S. at 82, 21 S.Ct. at 26 (citing Fay v. Cordesman, 109 U.S. 408, 3 S.Ct. 236 (1883)); Keystone Driller, 294 U.S. at 48, 55 S.Ct. at 265 (citing Royer v. Coure, 146 U.S. 524, 13 S.Ct. 166 (1892)); Exhibit Supply, 315 U.S. at 136, 62 S.Ct. at 518 (citing Goodyear, 102 U.S. 228 (1880)). The Warner-Jenkinson Court clearly endorsed the methodology applied in this pedigree of earlier Supreme Court cases spanning back to the nineteenth century. I believe that Warner-Jenkinson reaffirms the principles the Court set forth in Goodyear and Hurlbut, and underscores that these nine cases remain binding on this court today.

### III. Federal Circuit Authority

As noted above, I recognize that today's en banc court has the authority to overrule prior decisions of this court, and thus that our prior decisions applying flexible or measured estoppel are not binding on the en banc court. I present the following review of our case law, however, to highlight the magnitude of today's sudden shift, and to suggest that the approach of today's majority is contrary to any notion that judge-made law should evolve in a consistent, gradual, and predictable fashion.

**A. Our Adoption of Flexible Estoppel in 1983 Established the Only True “Line of Authority” in This Circuit.**

Consistent with Goodyear, Hurlbut, and the other Supreme Court cases reviewed above, this court has held in over fifty decisions that the scope of estoppel is measured by the scope of surrender. In Hughes Aircraft Co. v. United States, 717 F.2d 1351, 219 USPQ 473 (Fed. Cir. 1983) (Markey, Davis, Baldwin)<sup>14</sup> (“Hughes I”), this court rejected a “wooden application of estoppel,” and held that the application of prosecution history estoppel does not strip a patentee of all resort to the doctrine of equivalents. Id. The court stated:

Depending on the nature and purpose of an amendment, it may have a limiting effect within a spectrum ranging from great to small to zero. The effect may or may not be fatal to application of a range of equivalents broad enough to encompass a particular accused product. It is not fatal to application of the doctrine itself.

Id. (emphasis added).

Today’s majority, however, suggests that since Hughes I, this court has established two “lines of authority” adopting “inconsistent” views on the scope of prosecution history estoppel: one school originating with Hughes I favoring flexible estoppel; and a second school originating with Kinzenbaw v. Deere & Co., 741 F.2d 383, 222 USPQ 929 (Fed. Cir. 1984) (Friedman, Markey, Rich, Davis, Baldwin), favoring a complete bar. I disagree with that assessment. In my opinion, there is only one “line of authority.” While the majority correctly notes that Professor Chisum opines that there are “two lines of authority,” it neglects to mention that the second “line” consists of only two cases. See Chisum, supra, § 18.05[3][b][i], at 18-496 (“Two Federal Circuit panel decisions articulated the strict approach to estoppel.”) (emphasis

added). Kinzenbaw and Prodyne Enterprises, Inc. v. Julie Pomerantz, 743 F.2d 1581, 223 USPQ 477 (Fed. Cir. 1984) (Rich, Friedman, Cowen), however, do not hold that the mere fact of amendment triggers a complete estoppel; they simply stand for the rule that courts will not undertake a “speculative inquiry” into whether a claim amendment was necessary. Kinzenbaw, 741 F.2d at 389, 222 USPQ at 933; Prodyne, 743 F.2d at 1583, 223 USPQ at 478.

It is true that Kinzenbaw and Prodyne contain language which, taken alone, is arguably consistent with the complete bar imposed by the court today. On its face, however, neither opinion departs from our seminal ruling only the year before in Hughes I. In fact, each opinion purports to follow and quotes Hughes I. See Kinzenbaw, 741 F.2d at 389, 222 USPQ at 933 (“An applicant for patent . . . is not required to predict all future developments which enable the practice of his invention in substantially the same way.”) (quoting Hughes I, 717 F.2d at 1362, 219 USPQ at 481); Prodyne, 743 F.2d at 1583, 223 USPQ at 478 (“The doctrine of prosecution history estoppel precludes a patent owner from obtaining a claim construction that would resurrect subject matter surrendered during the prosecution of his patent application.”) (quoting Hughes I, 717 F.2d at 1362, 219 USPQ at 481).

Further, a close reading of the opinion in each case shows that rather than substituting a complete bar for flexible estoppel based on actual surrender, the panels did indeed look to the exact scope of surrender. They simply found that the surrender covered the accused subject matter. See Kinzenbaw, 741 F.2d at 389, 222 USPQ at 933 (“Instead, [the accused infringer] adopted the very element that [the patentee] had

eliminated for the stated purpose of avoiding the examiner's rejection and obtaining the patent."); Prodyne, 743 F.2d at 1583, 223 USPQ at 478 ("Prodyne is estopped from now broadening the description of a claim element limited during prosecution so as to encompass a structure which a competitor should reasonably be entitled to believe is not within the legal boundaries of the patent claims in suit."). In light of the holdings of these two cases, apart from the language the majority relies on, I cannot agree with my colleagues that we have established two conflicting lines of authority regarding prosecution history estoppel.

**B. This Court's Original Interpretation of Warner-Jenkinson Was Sound, and the Majority Has Not Explained Why We Should Overrule Our Earlier Cases.**

This court has issued a series of decisions since Warner-Jenkinson in which we have consistently interpreted Supreme Court law to require flexible estoppel. Today's majority, however, fails to provide a satisfactory explanation as to why we should overrule our earlier cases. In Litton Sys., Inc. v. Honeywell, Inc., 140 F.3d 1449, 46 USPQ2d 1321 (Fed. Cir. 1998) (Rader, Newman, Bryson), one of the three cases remanded to us in light of the Supreme Court's ruling in Warner-Jenkinson, this court, in 1998, most emphatically adhered to the "longstanding doctrine that an estoppel only bars recapture of that subject matter actually surrendered during prosecution." Litton, 140 F.3d at 1455, 46 USPQ2d at 1325. Our court clearly stated that "the application of prosecution history estoppel does not necessarily limit a patentee to the literal language of the amended element -- even when an amendment has been made to overcome the prior art." Id. We reasoned that the Warner-Jenkinson Court did not intend to "change so substantially the rules of the game" concerning the scope of estoppel. Id. at 1457, 46 USPQ2d at 1326 (citation omitted). We further noted that "the entire context of the

Warner-Jenkinson opinion shows that the Supreme Court approved the PTO's practice of requesting amendments with the understanding that the doctrine of equivalents would still apply to the amended language." Id. at 1456-57, 46 USPQ2d at 1326.

Similarly, in Hughes Aircraft Co. v. United States, 140 F.3d 1470, 46 USPQ2d 1285 (Fed. Cir. 1998) (Archer, Rader, Bryson) ("Hughes II"), issued the same day as Litton, a different panel of this court indicated that "the key to prosecution history estoppel is the surrender or disclaimer of the subject matter by the patentee, which the patentee is then unable to reclaim through the doctrine of equivalents." Id. at 1476, 46 USPQ2d at 1290 (referring to Exhibit Supply, 315 U.S. at 136, 62 S.Ct. at 518-19; Sutter, 119 U.S. at 541, 7 S.Ct. at 381-82). While amendments "serve to narrow the range of equivalents," not all equivalents are precluded. Id. We interpreted Warner-Jenkinson as supporting the proposition that courts may inquire into the reason for an amendment in order to "determine what subject matter the patentee actually surrendered." Hughes II, 140 F.3d at 1470, 46 USPQ2d at 1290 (citing Warner-Jenkinson 520 U.S. at 33 n.7, 117 S.Ct. at 1051 n.7).

Indeed, the very same year, in Cybor Corp. v. FAS Tech., Inc., 138 F.3d 1448, 46 USPQ2d 1169 (Fed. Cir. 1998) (en banc) (Archer), our court, sitting en banc, stated that "[t]he relevant inquiry is whether a competitor would reasonably believe that the applicant had surrendered the relevant subject matter." Id. at 1457, 46 USPQ2d at 1178. I fail to see how the majority will stabilize application of the doctrine of equivalents by overruling an en banc decision that is only two years old.

Only last year, in Sextant Avionique, S.A. v. Analog Devices, 172 F.3d 817, 49 USPQ2d 1865 (Fed. Cir. 1999) (Lourie, Smith, Gajarsa), this court followed Supreme

Court guidance in determining the novel question whether the Warner-Jenkinson presumption of a complete bar applies to both explained and unexplained amendments. See id. at 832, 49 USPQ2d at 1875. The Sextant court looked to the policies “foster[ed]” in Warner-Jenkinson to guide its reasoning. See id. at 831, 49 USPQ2d at 1875. The court noted that the Warner-Jenkinson Court created the presumption of a bar because “claims . . . serve both a definitional and public notice function.” See id. (citing Warner-Jenkinson, 520 U.S. at 33-35, 117 S.Ct. at 1051).

The court noted:

This policy of “public notice” is heavily implicated in the circumstance in which the presumption is operative because, by definition, it is unclear to one reading the prosecution history why a particular amendment was made. Accordingly, the Court, through the operation of the presumption, placed the burden on the patentee to clarify his reasons. The patentee’s failure to so clarify and thereby rebut the presumption should not work to the detriment of the public by allowing an uncertain range of equivalency to remain as to the limitation at issue.

Id. at 832, 49 USPQ2d at 1875. The panel concluded that a complete bar applies when the Warner-Jenkinson presumption arises and remains unrebutted. See id. (“Unguided by the prosecution history, the prior art, applicant’s argument during prosecution, and sufficient evidence in rebuttal to the presumption, we have no way to set reasonable limits on how far beyond the literal scope of the term . . . the estoppel will allow the doctrine of equivalents to reach.”). The court stated that under Warner-Jenkinson, courts must apply “a different rule of scope” when an amendment is unexplained. Id. at 831, 49 USPQ2d at 1874 (emphasis added). In the circumstance of an explained amendment, however, the Sextant court explicitly followed Supreme Court and Federal Circuit precedent in allowing the patentee a scope of protection from infringement by equivalents. See id. at 831, 49 USPQ2d at 1874 (citing Keystone

Driller Co., 294 U.S. at 47-48, 55 S.Ct. 262, and Magic City, 282 U.S. at 788-90, 51 S.Ct. at 291). The Sextant court noted that “Supreme Court case law predating Warner-Jenkinson embraced the concept of scope in the context of amendments made to avoid prior art.” Id.

In my opinion, today’s majority has not set forth a credible explanation as to why it is overruling our prior case law interpreting Warner-Jenkinson. The majority merely asserts, citing only “our long experience with the flexible bar approach,” that the standard we have applied until now is “unworkable.” I feel that we owe greater deference to our past interpretations of Supreme Court law, or a better explanation of why our case law is suddenly seen as “unworkable.”

**C. From 1983 to 2000, This Court Has Consistently Applied Flexible, or Measured, Estoppel.**

Panels of this court have consistently followed Hughes I and flexible estoppel. Indeed, in a parade of cases, from each year of this court’s eighteen-year history, successive and randomly-selected panels of this court have unanimously applied the flexible bar rule, and done so without mention of its newly-discovered “unworkability.” As the list below indicates, our court has embraced flexible estoppel in more than fifty cases. Ironically, these cases were decided by panels including nearly every member of today’s majority. In fact, most of the members of today’s majority have written an opinion, and indeed have done so since Warner-Jenkinson, supporting flexible preclusion.

To highlight the degree by which today’s majority departs from our settled law, I have provided the following list of cases that today’s ruling overturns.

## Federal Circuit Cases Applying Flexible Estoppel: 1983-2000

**1983:** Hughes Aircraft Co. v. United States, 717 F.2d 1351, 1362, 219 USPQ 473, 481 (Fed. Cir. 1983) (Markey, Davis, Baldwin): (“We, as has the Supreme Court, reject the view [that amendment bars all resort to the doctrine of equivalence] as a wooden application of estoppel, negating entirely the doctrine of equivalents and limiting determination of the infringement issue to consideration of literal infringement alone.”).

**1984:** Bayer Aktiengesellschaft v. Duphar Int’l Research B.V., 738 F.2d 1237, 1243, 222 USPQ 649, 653 (Fed. Cir. 1984) (Kashiwa, Cowen, Bennett) (“[W]henver the doctrine of file history estoppel is invoked, a close examination must be made as to, not only what was surrendered, but also the reason for such a surrender. The fact that claims were narrowed does not always mean that the doctrine of file history estoppel completely prohibits a patentee from recapturing some of what was originally claimed.”).

**1985:** Loctite Corp. v. Ultraseal Ltd., 781 F.2d 861, 871, 228 USPQ 90, 96 (Fed. Cir. 1985) (Baldwin, Davis, Kashiwa).

**1986:** Mannesmann Demag Corp. v. Engineered Metal Prod. Co., Inc., 793 F.2d 1279, 1284, 230 USPQ 45, 48 (Fed. Cir. 1986) (Newman, Baldwin, Cowen) (“Amendment of claims during patent prosecution does not necessarily bar all benefit of the doctrine of equivalents.”); Great Northern Corp. v. Davis Core & Pad Co., Inc., 782 F.2d 159, 166, 228 USPQ 356, 359-60 (Fed. Cir. 1986) (Rich, Markey, Kashiwa); Moeller v. Ionetics, Inc., 794 F.2d 653, 659, 229 USPQ 992, 996 (Fed. Cir. 1986) (Nichols, Friedman, Smith); Chemical Eng’g Corp. v. Esfef Indus., Inc., 795 F.2d 1565, 1573 n.8, 230 USPQ 385, 391 n.8 (Fed. Cir. 1986) (Markey, Rich, Baldwin).

**1987:** Townsend Eng’g Co. v. Hitec Co., Ltd., 829 F.2d 1086, 1090, 4 USPQ2d 1136, 1139 (Fed. Cir. 1987) (Friedman, Baldwin, Newman); Tandon Corp. v. United States Int’l Trade Comm’n, 831 F.2d 1017, 1026, 4 USPQ2d 1283, 1290 (Fed. Cir. 1987) (Newman, Friedman, Archer); Pennwalt Corp. v. Durand-Wayland, Inc., 833 F.2d 931, 939 n.2, 4 USPQ2d 1737, 1743 n.2 (Fed. Cir. 1987) (en banc).

**1988:** Hi-Life Prod., Inc. v. American Nat’l Water-Mattress Corp., 842 F.2d 323, 325, 6 USPQ2d 1132, 1134 (Fed. Cir. 1988) (Bissell, Markey, Davis); Water Techs. Corp. v. Calco, Ltd., 850 F.2d 660, 667, 7 USPQ2d 1097, 1102 (Fed. Cir. 1988) (Nies, Archer, Skelton); Diversitech Corp. v. Century Steps, Inc., 850 F.2d 675, 681, 7 USPQ2d 1315, 1320 (Fed. Cir. 1988) (Newman, Davis, Archer).

**1989:** LaBounty Mfg., Inc. v. United States Int’l Trade Comm’n, 867 F.2d 1572, 1576, 9 USPQ2d 1995, 1999 (Fed. Cir. 1989) (per curiam) (Nies, Bissell, Archer) (“[T]he breadth of the amendment does not necessarily equate with the breadth of the resulting estoppel.”); Sun Studs, Inc. v. ATA Equip. Leasing, Inc., 872 F.2d 978, 987, 10 USPQ2d 1338, 1345 (Fed. Cir. 1989) (Newman, Friedman, Bennett) (“The scope of estoppel must be determined in light of the prior art that occasioned the change, as well as representations made to the patent examiner as to the reason for the change.”);

Environmental Instruments, Inc. v. Sutron Corp., 877 F.2d 1561, 1566, 11 USPQ2d 1132, 1136 (Fed. Cir. 1989) (Rich, Nies, Michel); Black & Decker, Inc. v. Hoover Serv. Ctr., 886 F.2d 1285, 1295, 12 USPQ2d 1250, 1258 (Fed. Cir. 1989) (Markey, Newman, Archer).

**1990:** Jonsson v. Stanley Works, 903 F.2d 812, 817, 14 USPQ2d 1863, 1868 (Fed. Cir. 1990) (Re, Markey, Newman); Hormone Research Found., Inc. v. Genentech, Inc., 904 F.2d 1558, 1564, 15 USPQ2d 1039, 1044 (Fed. Cir. 1990) (Archer, Cowen, Michel); Insta-Foam Prods., Inc. v. Universal Foam Sys., Inc., 906 F.2d 698, 703, 15 USPQ2d 1295, 1298 (Fed. Cir. 1990) (Archer, Mayer, Skelton).

**1991:** Dixie USA, Inc. v. Infab Corp., 927 F.2d 584, 588, 17 USPQ2d 1968, 1970-71 (Fed. Cir. 1991) (Lourie, Mayer, Friedman) (“Appellants argue that they should be able to obtain some degree of equivalence even in the face of prosecution history estoppel, and that a total preclusion of equivalence should not apply. As a general proposition, that principle is correct . . .”); Vaupel Textilmaschinen KG v. Meccanica Euro Italia S.P.A., 944 F.2d 870, 882, 20 USPQ2d 1045, 1054 (Fed. Cir. 1991) (Lourie, Newman, Rader); Laitram Corp. v. NEC Corp., 952 F.2d 1357, 1361, 21 USPQ2d 1276, 1279-80 (Fed. Cir. 1991) (Newman, Archer, Rader).

**1992:** Charles Greiner & Co., Inc. v. Mari-Med Mfg., Inc., 962 F.2d 1031, 1036, 22 USPQ2d 1526, 1530 (Fed. Cir. 1992) (Rader, Plager, Smith).

**1993:** Texas Instruments, Inc. v. United States Int’l Trade Comm’n, 988 F.2d 1165, 1174, 26 USPQ2d 1018, 1025 (Fed. Cir. 1993) (Clevenger, Nies, Kaufman) (“Application of this test [to determine whether the patentee may assert the doctrine of equivalents,] requires, in each case, examination of the prosecution history taken as a whole.”); Wang Labs., Inc. v. Toshiba Corp., 993 F.2d 858, 26 USPQ2d 1767 (Fed. Cir. 1993) (Lourie, Archer, Clevenger); Hoganas AB v. Dresser Indus., Inc., 9 F.3d 948, 951, 28 USPQ2d 1936, 1939 (Fed. Cir. 1993) (Plager, Smith, Clevenger).

**1994:** Genentech, Inc. v. Wellcome Found. Ltd., 29 F.3d 1555, 1567, 31 USPQ2d 1161, 1170 (Fed. Cir. 1994) (Plager, Cowen, Lourie).

**1995:** Southwall Techs., Inc. v. Cardinal IG Co., 54 F.3d 1570, 1579, 34 USPQ2d 1673, 1676 (Fed. Cir. 1995) (Michel, Lourie, Bryson); Pall Corp. v. Micron Separations, Inc., 66 F.3d 1211, 1219, 36 USPQ2d 1225, 1230 (Fed. Cir. 1995) (Newman, Rich, Mayer).

**1996:** Modine Mfg., Co. v. United States Int’l Trade Comm’n, 75 F.3d 1545, 1556, 37 USPQ2d 1609, 1616 (Fed. Cir. 1996) (Newman, Mayer, Clevenger); Athletic Alternatives, Inc. v. Prince Mfg., Inc., 73 F.3d 1573, 1582, 37 USPQ2d 1365, 1373 (Fed. Cir. 1996) (Michel, Nies, Clevenger); Insituform Tech., Inc. v. CAT Contracting, Inc., 99 F.3d 1098, 1101, 40 USPQ2d 1602, 1609 (Fed. Cir. 1996) (Michel, Archer, Schall).

**1997:** Hilton Davis Chem. Co. v. Warner-Jenkinson Co., Inc., 62 F.3d 1512, 1525, 35 USPQ2d 1641, 1651 (Fed. Cir. 1997) (per curiam); Wang Labs., Inc. v. Mitsubishi Elecs. Amer., Inc., 103 F.3d 1571, 1578, 41 USPQ2d 1263, 1269 (Fed. Cir. 1997) (Rich, Mayer, Schall); Lockwood v. American Airlines, Inc., 107 F.3d 1565, 1574-75, 41 USPQ2d 1961, 1968 (Fed. Cir. 1997) (Lourie, Mayer, Rader).

**1998:** Cybor Corp. v. FAS Tech., Inc., 138 F.3d 1448, 1460, 46 USPQ2d 1169, 1178 (Fed. Cir. 1998) (en banc) (Archer); Litton Sys., Inc. v. Honeywell, Inc., 140 F.3d 1449, 1455, 46 USPQ2d 1321, 1326 (Fed. Cir. 1998) (Rader, Newman, Bryson) (“In accord with the Supreme Court’s understanding, this court has repeatedly stated that application of prosecution history estoppel does not necessarily limit a patentee to the literal language of the amended element -- even when an amendment has been made to overcome the prior art.”); Hughes Aircraft Co. v. United States, 140 F.3d 1470, 1476, 46 USPQ2d 1285, 1290 (Fed. Cir. 1998) (Archer, Rader, Bryson) (“[T]he key to prosecution history estoppel is the surrender or disclaimer of subject matter by the patentee, which the patentee is then unable to reclaim through the doctrine of equivalents. . . . In evaluating the reason behind an amendment, a court must ‘determine what subject matter the patentee actually surrendered.’”); Laitram Corp. v. Morehouse Indus., Inc., 143 F.3d 1456, 1464, 46 USPQ2d 1609, 1615-16 (Fed. Cir. 1998) (Lourie, Michel, Skelton); EMI Group North Amer. Inc. v. Intel Corp., 157 F.3d 887, 897, 48 USPQ2d 1181, 1189 (Fed. Cir. 1998) (Newman, Plager, Bryson) (“Cancellation of a claim that is written broadly does not always generate an estoppel to narrower subject matter. The particular facts must be considered.”); Desper Prod., Inc. v. Qsound Labs, Inc., 157 F.3d 1325, 1338, 48 USPQ2d 1088, 1098 (Fed. Cir. 1998) (Plager, Clevenger, Gajarsa); Bai v. L&L Wings, Inc., 160 F.3d 1350, 1356, 48 USPQ2d 1674, 1679 (Fed. Cir. 1998) (Lourie, Rich, Rader); Insituform Tech., Inc. v. Cat Contracting, Inc., 161 F.3d 688, 692, 48 USPQ2d 1610, 1614 (Fed. Cir. 1998) (Michel, Archer, Schall).

**1999:** Pharmacia & UpJohn Co. v. Mylan Pharms., Inc., 170 F.3d 1373, 1377, 50 USPQ2d 1033, 1037 (Fed. Cir. 1999) (Lourie, Newman, Schall); Sextant Avionique, S.A. v. Analog Devices, Inc., 172 F.3d 817, 830-32, 49 USPQ2d 1865, 1870-72 (Fed. Cir. 1999) (Lourie, Smith, Gajarsa); Augustine Med. Inc. v. Gaymar Indus., Inc., 181 F.3d 1291, 1298, 50 USPQ2d 1900, 1905 (Fed. Cir. 1999) (Mayer, Rader, Gajarsa); Loral Fairchild Corp. v. Sony Corp., 181 F.3d 1313, 1323, 50 USPQ2d 1865, 1871 (Fed. Cir. 1999) (Archer, Michel, Plager); Merck & Co. v. Mylan Pharms. Inc., 190 F.3d 1335, 1341, 51 USPQ2d 1954, 1958 (Fed. Cir. 1999) (Newman, Lourie, Clevenger); K-2 Corp. v. Salomon S.A., 191 F.3d 1356, 1368, 52 USPQ2d 1001, 1008 (Fed. Cir. 1999) (Clevenger, Rader, Gajarsa) (In order to prevent infringers from “stealing the benefits of an invention, . . . the doctrine of equivalents must . . . remain within the boundaries established by the prior art, the scope of the patent claims themselves, and any surrendered subject matter.”).

**2000:** Bayer AG v. Elan Pharm. Research Corp., 212 F.3d 1241, 1251, 54 USPQ2d 1711, 1717 (Fed. Cir. 2000) (Schall, Clevenger, Bryson); KCJ Corp. v. Kinetic

Concepts, Inc., 223 F.3d 1351, 1358, 55 USPQ2d 1835, 1842 (Fed. Cir. 2000) (Rader, Plager, Clevenger).

IV. The Majority's Rule Likely Will Have Unintended and Adverse Consequences that Undermine the Policies Advanced by the Supreme Court's Interpretation of the Doctrine of Equivalents.

The doctrine of equivalents was created to prevent "fraud on a patent," such as near-literal copying of the claimed invention with the addition of merely insubstantial changes in order to avoid liability for literal infringement. Graver Tank & Mfg. Co. v. Linde Air Prods. Co., 339 U.S. 605, 608, 70 S.Ct. 854, 856 (1950). Winans v. Denmead, 56 U.S. 330 (1853), was the first Supreme Court case to address the doctrine of equivalents. In Winans, the Court adopted the doctrine in order to prevent precisely the abuse that today's ruling will allow, namely, the appropriation of patented inventions by making trivial modifications to a claimed device. The Court recognized that "the exclusive right to the thing patented is not secured, if the public are at liberty to make substantial copies of it, varying its form or proportions." Id. at 343. In Graver Tank, the Court reiterated the necessity of the doctrine of equivalents, stating:

[C]ourts have also recognized that to permit imitation of a patented invention which does not copy every literal detail would be to convert the protection of the patent grant into a hollow and useless thing. Such a limitation would leave room for--indeed encourage--the unscrupulous copyist to make unimportant and insubstantial changes and substitutions in the patent which, though adding nothing, would be enough to take the copied matter outside the claim, and hence outside the reach of law.

339 U.S. at 607, 70 S.Ct. at 856 (emphasis added).

Despite repeated petitions seeking to abolish the doctrine of equivalents, the Supreme Court has steadfastly ruled that patentees are entitled to its protection. See

Warner-Jenkinson, 520 U.S. at 21, 117 S.Ct. at 1045 (declining to “speak the death of that doctrine”). As a lower court, we must respect the Supreme Court’s decision to accord patentees the benefits of the doctrine of equivalents. I believe that the majority’s new rule, far from providing patentees the protections the Supreme Court has guaranteed, unfairly strips most patentees of the right to assert infringement under the doctrine of equivalents.

**A. Today’s Ruling Provides Copyists with a Fail-Safe Method to Avoid Liability for Infringement.**

The majority discusses the unpredictability of prosecution history estoppel under a flexible approach, and how its complete bar “eliminates the public’s need to speculate as to the subject matter surrendered by a narrowing claim amendment.” As a solution to this problem of the doctrine of equivalents, today’s ruling simply denies any resort to the doctrine, for amended claim limitations.

Today’s ruling will allow copyists to readily avoid liability despite practicing the substantial equivalent of the claimed invention. Anyone seeking to lawfully copy a patented technology will only have to adopt the following method: (1) read the prosecution history to identify amendments made for patentability reasons; (2) copy every other limitation exactly, but substitute any known interchangeable structure, matter, or step for any limitation that has been amended. Any change, no matter how “unimportant and insubstantial,” to even one amended limitation will be sufficient to avoid liability under the majority’s rule.

The ease and certainty with which this method can be applied may be readily appreciated with reference to cases such as Insituform Technologies, Inc. v. CAT Contracting, Inc., 99 F.3d 1098, 40 USPQ2d 1602 (Fed. Cir. 1996). The asserted

patent in Insituform claimed a process for impregnating the interior felt repair lining of an underground pipe with resin by using a cup attached over a hole on the outside of the pipe to apply a vacuum downstream of the resin. The resin is thereby made to flow along the interior of the pipe towards the vacuum, permeating the felt and curing it. See id. at 1103, 40 USPQ2d at 1605. The patentee had amended the asserted patent claim in response to an examiner's patentability rejection to include the limitation that the vacuum be applied sequentially in a stepwise fashion using a cup that was repeatedly removed from one location along the pipe and moved further downstream once the resin had profused near the original location of the cup. See id. at 1104, 40 USPQ2d at 1606.

A copyist's first step in exploiting today's ruling to avoid liability, then, would be to identify a claim limitation that was amended for patentability reasons. Here, that is the limitation requiring the successive application of a cup to different locations along the outside of the pipe. The second step, then, would be to determine the most convenient substitute for this limitation. In this case, the copyist could simply apply the vacuum simultaneously using two cups. As we held in Insituform, this would be sufficient to avoid literal infringement. 99 F.3d at 1106-07, 40 USPQ2d at 1608. And under today's ruling the amended limitation is not entitled to any protection under the doctrine of equivalents, so the copyist will have succeeded in avoiding all liability by simply practicing the claimed invention, but using two cups.

Because today's ruling completely eliminates protection against known substitutes for the amended limitation, any competitor adopting this method would be free from liability, as the amended limitation is not met literally but rather is supplied by

an obvious equivalent. To me, protection against such “close copying” is the central office of the doctrine of equivalents. The Supreme Court clearly warned of this danger in Graver Tank. See 339 U.S. at 607, 70 S.Ct. at 856 (“Outright and forthright duplication is a dull and very rare type of infringement. To prohibit no other would place the inventor at the mercy of verbalism and would be subordinating substance to form. It would deprive him of the benefit of his invention.”).

Prosecution history estoppel, moreover, is an equitable doctrine. By its very purpose, equity jurisprudence provides a remedy individually tailored to the circumstances of the dispute at hand. As stated by the Supreme Court:

The essence of equity jurisdiction has been the power of the Chancellor to do equity and to mould each decree to the necessities of the particular case. Flexibility rather than rigidity has distinguished it. The qualities of mercy and practicality have made equity the instrument for nice adjustment and reconciliation between the public interest and private needs as well as between competing private claims.

Hecht Co. v. Bowles, 321 U.S. 321, 329-30, 64 S.Ct. 587, 592 (1944) (emphasis added). Today’s ruling, however, imposes a rigid legal rule upon the application of the equitable doctrine of prosecution history estoppel. The complete bar eliminates the flexibility that equity demands. Without this flexibility, courts are precluded from protecting patentees from copyists.

**B. The Ability of Copyists to Avoid Liability Under the Complete Bar Will Be Particularly Severe in Certain Types of Technology.**

Copyists will be able to apply today’s ruling, using the fail-safe method noted above, to avoid liability in many, if not all, areas of technology. Biotechnology is one critical field of technology that may be particularly harmed by today’s ruling. Completely barring resort to the doctrine of equivalents for amended claim limitations may

drastically limit the scope of protection for biotechnology patents, such as those claiming a protein molecule. See Amicus Curiae Brief on behalf of Chiron Corporation in support of Respondent at 16, 17, Warner-Jenkinson (No. 95-728).

A protein molecule can only be claimed as the complete and specific sequence of amino acids comprising the protein. See 37 C.F.R. § 1.821 (2000). The particular amino acids that comprise a protein chain are frequently interchangeable with other amino acids without changing the protein or its functions. As our court noted with respect to a patent claiming the protein erythropoietin, “over 3,600 different [protein] analogs can be made by substituting [interchangeable acids] at only a single amino acid position, and over a million different analogs can be made by substituting three amino acids.” Amgen, Inc. v. Chugai Pharm. Co., 927 F.2d 1200, 1213, 18 USPQ2d 1016, 1026 (Fed. Cir. 1991). Many such analogs are functionally identical to the claimed protein. Thus, a competitor seeking to make, use, or sell a protein that is protected by a patent containing an amended claim limitation will only have to substitute at a particular location in the chain an interchangeable amino acid for the particular amino acid recited in the patent claim as occupying that location. It appears that, in order to thwart such copying, a patent applicant would have to disclose and claim every single analog that is functionally equivalent to the claimed protein. Considering the vast number of specific amino acid sequences that an applicant would be forced to disclose and claim in order to secure meaningful protection for his invention, I feel the majority’s rule puts an impossible burden on both the applicant and the PTO.

**C. Amending Claims for Patentability Reasons Is a Common Practice That Should Not Trigger a Complete Bar.**

The majority gives no hint of the magnitude of the effects that will ensue from its new rule. The vast majority of patent applications contain claims that are initially rejected in view of the prior art, and are only allowed after being amended. Patent prosecution is an iterative process in which the applicant typically submits claims that are thought to be allowable, the examiner rejects the claims in view of the prior art, and the applicant then amends the claims to traverse the examiner's patentability rejections. See, e.g., Hughes I, 717 F.2d at 1363, 219 USPQ at 481 (“Amendment of claims is a common practice in prosecution of patent applications. No reason or warrant exists for limiting application of the doctrine of equivalents to those comparatively few claims allowed exactly as originally filed and never amended.”).

Today's ruling may prove impractical because it provides that the mere act of amendment to traverse a patentability rejection eliminates all protection under the doctrine of equivalents, even for equivalents that were not the subject of the amendment. This is ill-suited to the iterative process by which patent applications are prosecuted. In Warner-Jenkinson, the Supreme Court refused to apply prosecution history estoppel regardless of the reason for amendment expressly because to do so would “subvert the various balances” inherent in the process of rejection followed by amendment. 520 U.S. at 32 n.6, 117 S.Ct. at 1050 n.6. In holding that any amendment made for patentability reasons triggers a complete bar to protection under the doctrine of equivalents, today's ruling will “subvert the various balances” inherent in the process of patent prosecution. Id.

Rather than acquiesce to patentability rejections and thereby surrender all recourse to the doctrine of equivalents, applicants will be increasingly likely to file

administrative and judicial appeals. The PTO Board of Patent Appeals and Interferences is already backlogged and often takes years to decide an appeal. Neither the PTO, nor our court, is prepared to handle any significant increase in such appeals. Such an increase could result in a significant lengthening in the average time and cost required to prosecute an application to issuance.

Furthermore, this court's imposition of a complete bar creates a perverse incentive for patent applicants, particularly those who are financially unable to invoke the appeals process, to simply abandon their applications. In many cases, it may be more effective to protect an invention by maintaining it as a trade secret than by accepting a patent that will publicize the invention, but provide protection only from literal infringement. See *Graver Tank*, 339 U.S. at 607, 70 S.Ct. at 856 (“[Protecting against only literal infringement] would deprive [the inventor] of the benefit of his invention and would foster concealment rather than disclosure of inventions, which is one of the primary purposes of the patent system.” (emphasis added)). As a result, the public may be deprived of useful teachings contained in patent applications that are simply abandoned after a rejection is made regarding a critical claim limitation.

**D. Today's Ruling Will Significantly, and Unfairly, Reduce the Value of All Unexpired Patents That Were Amended for Patentability Reasons.**

The effect of today's ruling upon previously-issued but unexpired patents may be dramatic. While I cannot predict all the consequences that may flow from today's decision, I think it is safe to say that the majority's rule will reduce the effective scope, and thus, the value, of most of the 1,200,000 patents that are unexpired and enforceable. Wholly apart from other long-term effects of the majority's rule, I feel that today's ruling will be unfairly disruptive of existing commercial relations. Today's ruling

offers no “grandfathering” provision for the vast numbers of unexpired patents that contain amended claim limitations, and thus that will become increasingly susceptible to copying under today’s new rule. Patent applicants who prosecuted their claims under the rule of a flexible bar will have protection limited now by our new rule of complete estoppel. As today’s adoption of the complete bar was utterly unpredictable, these applicants had no way to avoid the harm that now befalls them.

I think that today’s ruling might most directly impact untold numbers of licensing agreements that are predicated on the assumption that patent claims with an amended limitation are still entitled to a range of equivalents. Licensees will be tempted to exploit today’s ruling using the method for liability-free copying discussed above. A licensee could make a minor substitution of a known interchangeable element for an amended claim limitation, and then correctly claim that it is no longer practicing the patented -- and licensed -- invention. The licensor would then be powerless to enforce the license because the amended claim or claims simply would not cover the licensee’s newly-modified product or process.

As discussed above, the Supreme Court specifically refused in Warner-Jenkinson to “upset the basic assumptions” regarding prosecution history estoppel. See 520 U.S. at 32, 117 S.Ct. at 1050. I feel that today’s ruling will upset basic assumptions regarding the effective scope of patents, and will unfairly disrupt commercial relations based on these assumptions.

## **V. Conclusion**

In the face of over one hundred years of Supreme Court case law, today’s en banc majority lacks authority to establish a complete bar rule. The majority also

abruptly abandons eighteen years of unvarying Federal Circuit precedent as articulated in over fifty decisions, and does so without showing their error. Moreover, I believe that imposing a complete and automatic bar to the doctrine of equivalents for claim limitations amended for patentability reasons will have adverse, unfair, and unintended consequences. I accordingly must dissent from the majority's answer to Question 3.

# United States Court of Appeals for the Federal Circuit

95-1066

FESTO CORPORATION,

Plaintiff-Appellee,

v.

SHOKETSU KINZOKU KOGYO KABUSHIKI CO., LTD., a/k/a SMC CORPORATION,  
And SMC PNEUMATICS, INC.,

Defendants-Appellants.

RADER, Circuit Judge, concurring-in-part, dissenting-in-part

A primary justification for the doctrine of equivalents is to accommodate after-arising technology. Without a doctrine of equivalents, any claim drafted in current technological terms could be easily circumvented after the advent of an advance in technology. A claim using the terms “anode” and “cathode” from tube technology would lack the “collectors” and “emitters” of transistor technology that emerged in 1948. Thus, without a doctrine of equivalents, infringers in 1949 would have unfettered license to appropriate all patented technology using the out-dated terms “cathode” and “anode”. Fortunately, the doctrine of equivalents accommodates that unforeseeable dilemma for claim drafters. Indeed, in Warner-Jenkinson Co., Inc. v. Hilton Davis Chemical Co., 520 U.S. 17, 37 (1997), the Supreme Court acknowledged the doctrine’s role in accommodating after-arising technology.

Unfortunately, by barring all application of the doctrine of equivalents for amended claims, this court does not account at all for the primary role of the doctrine. All patent protection for amended claims is lost when it comes to after-arising

technology, while the doctrine of equivalents will continue to accommodate after-arising technology in unamended claims. For a reason far more important than disparate treatment of claims, however, this result defies logic.

Prosecution history estoppel is an estoppel doctrine. Estoppel prevents a litigant from denying an earlier admission upon which another has already relied.\* BLACK'S LAW DICTIONARY 570 (7th ed. 1999). In the case of patent law, the admission is the applicant's surrender of claim scope to acquire the patent. Today's rule forfeits all protection of the doctrine of equivalents whenever applicants amend their claims, regardless of whether they in fact surrendered coverage. By definition, applicants could not have surrendered something that did not even exist at the time of the claim amendment, namely after-arising technology.

The court reasons today that it will not inquire about the scope of an estoppel because it cannot with certainty ascertain the scope of the applicant's surrender. Although that premise is questionable for the reasons enunciated by Judges Michel and Linn, one thing is beyond question: That premise does not apply to after-arising technology. Because after-arising technology was not in existence during the patent application process, the applicant could not have known of it, let alone surrendered it. Nonetheless, the court would apply an estoppel where none exists and defeat the doctrine of equivalents.

---

\* This patent law version of "estoppel" varies from classical estoppel because an accused infringer need not have relied at all on the prior admission.

# United States Court of Appeals for the Federal Circuit

95-1066

FESTO CORPORATION,

Plaintiff-Appellee,

v.

SHOKETSU KINZOKU KOGYO KABUSHIKI CO., LTD. a/k/a/ SMC CORPORATION,  
and SMC PNEUMATICS, INC.,

Defendants-Appellants.

LINN, Circuit Judge, concurring-in-part, dissenting-in-part, in which Circuit Judge RADER joins.

I join the majority's articulate and well-reasoned answers to Questions 1, 2 and 4; however, I must, respectfully, dissent from the answer of the majority to Question 3 and from Part III, Section C of the opinion of the court. In my opinion, the majority's new rigid bright line rule, eliminating all flexibility in the scope afforded certain claim limitations amended for a statutory purpose just because they were amended for a statutory purpose, goes too far. The reasons expressed by the majority do not justify this dramatic policy shift.

With all due respect to my colleagues in the majority, the new bright line rule, as simple as it is hoped to be in application, wrongfully sets in place a regime that increases the cost and complexity of patent prosecution to the detriment of individual inventors, start-up companies, and others unable to bear these increased costs. The new regime also places greater emphasis on literary skill than on an inventor's

ingenuity; gives unscrupulous copyists a free ride on the coattails of legitimate inventors; and changes the rules under which prosecution strategies were formulated for thousands of extant patents no longer subject to correction. I find particularly apt here the concerns expressed by the Supreme Court in Warner-Jenkinson when it considered the petitioner's request for a bright line rule precluding "recapture" of any part of surrendered subject matter under the doctrine of equivalents: "[t]o change so substantially the rules of the game now could very well subvert the various balances the PTO sought to strike when issuing the numerous patents which have not yet expired and which would be affected by our decision." Warner-Jenkinson Co. v. Hilton Davis Chem. Co., 520 U.S. 17, 32 n.6 (1997).

In my opinion, the approach to prosecution history estoppel as articulated by the Supreme Court and long followed by this court should remain the rule. As long as the reason for an amendment is explained, an estoppel by amendment should only bar recapture of the subject matter actually surrendered, as discerned from the amended claim language and the reasons articulated by the applicant for the change. The mere fact that an amendment to a claim is made pursuant to a statutory requirement is insufficient in and of itself to conclude that all subject matter beyond the literal scope of the amended claim language has been surrendered, even where the amendment is made to overcome prior art.

Both by taking an expansive view of what constitutes a "substantial reason relating to patentability" and by applying prosecution history estoppel as a complete bar to any reliance on the doctrine of equivalents for claim limitations narrowed by amendment, the majority unfairly tips the balance away from patentees and toward

competitors by constraining the legitimate rights of patentees to their inventions, even where competitors can reasonably determine the reasons for any amendments and the scope of any subject matter surrendered. In my view, this is an ill-advised major policy shift that is neither compelled nor justified at this time.

## DISCUSSION

### Purpose of the Patent System

The Constitution authorizes Congress “[t]o promote the Progress of . . . useful Arts, by securing for limited Times to . . . Inventors the exclusive Right to their . . . Discoveries.” U.S. Const. art. I, § 8, cl. 8. The foregoing evinces the founding fathers’ intent that the federal patent laws of the United States be directed to the public purpose of fostering technological progress. See Hilton Davis Chem. Co. v. Warner-Jenkinson Co., Inc., 62 F.3d 1512, 1536, 35 USPQ2d 1641, 1660 (Fed. Cir. 1995) (en banc) (Newman, J., concurring), rev’d on other grounds, 520 U.S. 17 (1997).

An exclusive right granted by the government for one’s invention has value to an inventor as a guarantee of protection, and, thus, stimulates inventors to add to the sum of human knowledge. See Paul C. Craane, At The Boundaries Of Law And Equity: The Court Of Appeals For The Federal Circuit And The Doctrine Of Equivalents, 13 N. Ill. U. L. Rev. 105, 107-08 (1992). To obtain this exclusive right, the inventor must disclose his invention to the public. Thus, the patent also is of value to the public because such disclosures will stimulate others to add to the sum of human knowledge through the creation of other inventions utilizing the lessons learned by the patentee. See id. at 108-09.

Strong patent protection is key to encouraging innovation, economic growth, and American competitiveness. See Paul J. Otterstedt, Unwrapping File Wrapper Estoppel

In The Federal Circuit: A New Economic Policy Approach, 67 St. John's L. Rev. 405, 422 (1993). “From their inception, the federal patent laws have embodied a careful balance between the need to promote innovation and the recognition that imitation and refinement through imitation are both necessary to invention itself and the very life blood of a competitive economy.” Bonito Boats, Inc. v. Thunder Craft Boats, Inc., 489 U.S. 141, 146 (1989). Thus, the patent laws attempt to provide each inventor with reasonable assurances that the reward to which he or she is entitled will, in fact, be given. And, these same laws also attempt to provide competitors with notice of the patent owner’s rights. Strong patent protection must both accommodate and balance justice to the patentee and notice to the public of the patentee’s rights.

#### Claims Use Ordinary Language to Capture Concepts

To protect an invention through the United States patent laws, an inventor must use patent “claims.” See 35 U.S.C. § 112, second paragraph (1994). The purpose of this requirement is to give notice of the technology that the patent controls. See Slimfold Mfg. Co. v. Kinkead Indus., 932 F.2d 1453, 1457 (Fed. Cir. 1991) (“Inherent in our claim-based patent system is . . . the principle that the protected invention is what the claims say it is, and thus that infringement can be avoided by avoiding the language of the claims.”)

There is no disputing that an inventor is free to craft claims any way he sees fit to “particularly point[] out and distinctly claim[] the subject matter [that he] regards as his invention.” 35 U.S.C. § 112, second paragraph. However, a claim is a linguistic description of a mental concept. Due to the inherent limitations of language, the fit between the description and the concept is almost always inexact. See Br. for Amicus

Curiae Fed. Cir. Bar Assoc. in Hilton Davis Chem. Co. v. Warner-Jenkinson, Inc., Appeal No. 93-1088, 3 Fed. Cir. B.J. 345, 348 (1993). In addition to the inexact fit caused by the inherent limitations of language, the language itself may not be adequately developed at the early stages when patent applications typically are filed, particularly in rapidly evolving research fields.

Besides the foregoing language issues, the early patent application filings encouraged by the U.S. patent laws give rise to additional difficulties in crafting a claim that particularly points out the subject matter that the inventor regards as his invention. For inventions in rapidly evolving fields, application filings are often made while the inventions are still in their nascent stages, i.e., early in the evolutionary process, necessitating inevitable and sometimes considerable fine tuning of claim language after the initial application filings have been made. Moreover, while an inventor is often aware of relevant prior art relating to the area he is developing, he is not always fully cognizant of all of the relevant prior art until after his application has been filed, thus again necessitating some fine tuning of claim language after the initial application filing has been made.

As a consequence of the foregoing, it is quite difficult for claim drafters to draft initial claims that adequately and accurately cover the “invention” on the day the patent application is filed. Consequently, claims are commonly amended during prosecution to more particularly point out and distinctly claim that which is regarded to be the invention. See Loctite Corp. v. Ultraseal Ltd., 781 F.2d 861, 871, 228 USPQ 90, 96 (Fed. Cir. 1985) (noting that comparatively few claims are allowed exactly as originally filed), overruled on other grounds by Nobelpharma AB v. Implant Innovations, Inc., 141

F.3d 1059, 46 USPQ2d 1097 (Fed. Cir. 1998); Hughes Aircraft Co. v. United States, 717 F.2d 1351, 1363, 219 USPQ 473, 481 (Fed. Cir. 1983); Litton Sys. Inc., v. Honeywell, Inc., 140 F.3d 1449, 1455, 46 USPQ2d 1321, 1325 (Fed. Cir. 1998).

While the majority opinion is very clear that the court's new bright line rule applies only to claim limitations narrowed by amendment, it does not articulate with like clarity what it considers to be a "narrowing" amendment. In drafting an original claim of a patent application, the writer sets out the metes and bounds of the invention using words in their ordinary sense or in any special sense ascribed to those words in the written description. When the claim drafter amends the terms used in the original claims, such as by adding an adjective or choosing a different word than originally used, such changes will serve to more distinctly point out that which is the invention and ordinarily, though not inevitably, will signify a difference in intended claim coverage. If the change is merely the substitution of one synonymous word for another or the mere clarification of language from a foreign translation, the claim drafter may intend no change whatsoever in claim scope; but the drafter's word choice may be construed after grant of the patent to imply a different scope simply because changes to claim language are not made merely for aesthetic reasons. However, just because the claim drafter amends a claim limitation, does not mean he "intends" to narrow the scope of his claim coverage or to give up all subject matter beyond the literal scope of the amended language. The only inference one should draw from the mere fact alone that an amendment was made is that the claim drafter "intends" the patent to be issued. See Glenn K. Beaton, File Wrapper Estoppel And The Federal Circuit, 68 Denv. U. L. Rev. 283, 286 (1991) (noting that the patentee presumably "intends" that his reward for

promoting the progress of the useful arts be as great as possible and that the limits to his reward be as small as possible).

#### Doctrine of Equivalents: Borne of Equity

“That the claims of a patent should be clear and should control the determination of infringement has been emphasized by the Supreme Court for over a century.” Donald S. Chisum, The Scope Of Protection For Patents After The Supreme Court's Warner-Jenkinson Decision: The Fair Protection-Certainty Conundrum, 14 Santa Clara Computer & High Tech. L.J. 1, 6 (1998) (citing 5 Donald S. Chisum, Chisum on Patents, §8.02[3] (1997)); Merrill v. Yeomans, 94 U.S. 568, 573-74 (1877) (“[N]othing can be more just and fair, both to the patentee and to the public, than that the former should understand, and correctly describe, just what he has invented and for what he claims a patent.”) Nevertheless, the Supreme Court has recognized that “strict and literal adherence to the written claim in determining the scope of protection [to afford to a patentee] can invite subversion of a valuable right and substantially diminish the economic value of patents.” Chisum, supra, at 6 (citing Chisum on Patents, supra, §18.02); see also Graver Tank & Mfg. Co. v. Linde Air Prods. Co., 339 U.S. 605, 607 (1950). In other words, a system of protection for patentees limited to literal infringement subjects the patentee to the mercy of verbalism and “would convert the protection of the patent grant into a hollow and useless thing.” Graver Tank, 339 U.S. at 607.

Thus, “[t]o temper unsparing logic and prevent an infringer from stealing the benefit of the invention” and thereby ensure that the patent grant is not converted into a useless thing by being subject to the mercy of verbalism, the Supreme Court embraced the doctrine of equivalents. Id. at 608 (quoting Judge Learned Hand in Royal

Typewriter Co. v. Remington Rand, 168 F.2d 691, 692 (2d Cir. 1948)). This doctrine was borne of equity to allow room for justice to the patentee against those who manage to avoid the letter of the invention as it was claimed in the patent through “unimportant and insubstantial changes.” Id. at 607; see Harold C. Wegner, Equitable Equivalents: Weighing the Equities to Determine Patent Infringement in Biotechnology and Other Emerging Technologies, 18 Rutgers Computer & Tech. L.J. 1, 6-16 (1992) (providing a definitive discussion of the origin of the doctrine of equivalents); Donald R. Dunner & J. Michael Jakes, The Equitable Doctrine of Equivalents, 75 J. Pat. & Trademark Off. Soc’y 857, 859 (1993) (“[T]he doctrine of equivalents did not originate strictly as a way to catch infringers who avoided the literal language of patent claims [since the doctrine of equivalents dates back long before peripheral claiming]. The doctrine was primarily an equitable one, to be applied against copyists who made only slight changes in the form of the invention.”); but see Robert P. Taylor and Celine T. Callahan, The Doctrine of Equivalents After Hilton Davis: Many Unanswered Questions, 489 PLI/Pat 7, 26-27 (1997) (noting that the Supreme Court in Warner-Jenkinson appears to have held that the doctrine of equivalents is not a doctrine of equity).

While it is generally agreed that the doctrine of equivalents stands at the intersection of justice to the patentee and notice to competitors of the patentee’s rights, the United States patent law embraces this conflict to provide an inventor with security in the patent rights granted by the law and to stimulate technological progress. See Graver Tank, 339 U.S. at 607 (noting that subjecting the inventor to the mercy verbalism would deprive the inventor of his invention and would foster concealment rather than disclosure of invention); see also Hilton Davis, 62 F.3d at 1531, 35 USPQ2d

at 1656 (Newman, J., concurring) (noting that the dependence of industry on technology, the reduced opportunity to rely on trade secrecy because of today's enlarged analytical capability, the ease and speed of imitation and modification once the innovator has shown the way, the harshness of modern competition, and the ever-present need for industrial incentives are factors that favor a rule that tempers the rigor of literalness); Wegner, supra, at 31-32 (noting that "[p]atent protection that can be easily circumvented is antithetical to building a strong research-based industrial technology").

The problems noted above regarding the inherent limitations of language and the early stage of filing applications have provided justification for the lengthy history of applying the doctrine of equivalents to all claim language to adequately protect the patentee's right to his invention, despite the public notice function the claim terms serve. Even with the majority's new rule, these concepts continue to provide justification for the application of the doctrine of equivalents to original claim language.

In my opinion, the majority's new bright line rule eliminating all flexibility in the scope of claim limitations amended for a statutory purpose reflects an unjustified faith in the draftsman to select language to perfectly describe a new and unobvious invention at an early stage of the development process. The same limitations of language noted in selecting words to describe an invention in the first instance are no less present in selecting words to avoid an examiner's rejection of that original language for one statutory reason or another.

Furthermore, the majority's new rule will substantially increase the cost of obtaining patent protection, and may in fact become prohibitively high for individual

inventors and start-up companies. It will require applicants to undertake exhaustive pre-filing searches, which will not only be costly but also time consuming. It will also require applicants to file in an original application numerous “narrow” claims or, if “broad” claims are sought, to be prepared to argue to the patent examiner, to the board of appeals, and to this court the impropriety of all rejections for patentability reasons, rather than to amend those claims, given the harsh consequences of amendments under the majority’s new bright line rule. It will also deter applicants from attempting to expedite prosecution and attain early allowance by making minor or clarifying amendments to the claims, either in anticipation of the initial office action or at subsequent times during prosecution, for fear of triggering a complete bar to later reliance on the doctrine of equivalents. This will result in protracted prosecution and dramatically increased costs for many applications. These increases in costs and complexity will also come at a time when greater prosecution investments may be hard for many applicants to justify because the commercial value of the inventions covered may not then be fully apparent. In my view, this will most detrimentally impact individual inventors and start-up companies, and may have the effect of impeding, not advancing, technological progress, contrary to the purpose of the patent system.

#### Warner-Jenkinson’s Effect on the Doctrine of Equivalents

While I agree with the majority that the question of the scope of equivalents available to a claim element that has been amended for a known patentability reason was not directly addressed by Warner-Jenkinson, the Supreme Court did discuss the fact that an amendment to a claim element “does not necessarily preclude infringement by equivalents of that element.” Warner-Jenkinson, 520 U.S. at 33. In fact, where the record reveals a reason for the claim amendment, the Court noted that those “reasons

for a claim amendment may avoid application of prosecution history estoppel.” Id. In addition, the Court recognized that whether or not prosecution history estoppel is avoided will depend upon the “reason (right or wrong) for the [examiner’s rejection of the claim prior to its being amended] and the manner in which the amendment addressed and avoided that [rejection].” Id. at 33 n.7.<sup>15</sup>

After specifically stating that the reasons for a claim amendment are relevant to any subsequent application of prosecution history estoppel as a bar to the application of the doctrine of equivalents, see id. at 30-32, the Court noted that the definitional and notice functions of the claims require the patentee to establish a reason for an amendment in order to avoid the estoppel, see id. at 33. In the absence of a reason, the Court explained that “prosecution history estoppel would bar the application of the doctrine of equivalents as to that element,” because it would be presumed that the

---

<sup>15</sup> While it is true that footnote 7 was directed to a claim change made relative to avoiding the prior art, presumably the same methodology was meant to apply to claims amended for other reasons, since the Court set forth the methodology just after stating in the body of the opinion: “[w]here the reason for the [claim] change was not related to avoiding the prior art, . . . [the change] does not necessarily preclude infringement by equivalents of that element.” Warner-Jenkinson, 520 U.S. at 33.

limiting element added by amendment was for a substantial reason related to patentability. Id. The Court determined that “[a]ppplied in this fashion, prosecution history estoppel places reasonable limits on the doctrine of equivalents, and further insulates the doctrine from any feared conflict with the Patent Act.” Id. at 34.

If the doctrine of equivalents is completely barred when no reason for an amendment can be discerned from the prosecution history, and it is likewise completely barred when a reason is stated, what is the point of exploring the “reason (right or wrong) for the [examiner’s rejection of the claim prior to its being amended] and the manner in which the amendment addressed and avoided that [rejection?]” Id. at 33 n.7. Thus, adoption of a rebuttable presumption of estoppel for an amendment that was made for an unknown reason necessarily presupposes the possibility that no estoppel will apply where the reason for the amendment is known, or where the presumption is rebutted.

The petitioner argued to the Supreme Court in Warner-Jenkinson that “any surrender of subject matter during patent prosecution, regardless of the reason for such surrender, precludes recapturing any part of that subject matter, even if it is equivalent to the matter expressly claimed.” Id. at 30. The Supreme Court rejected that argument. See id. I think it is fair to conclude that Warner-Jenkinson reaffirmed the long standing principle applied by this court before today that to determine the scope of prosecution history estoppel, if any, to be applied to an amended claim limitation with reasons extant in the prosecution file, one must look to the exchange between the examiner and

the patentee in the prosecution file to determine that which was surrendered by the patentee in making the amendment.<sup>16</sup>

In applying the majority's new rule, a court does not explore the exchange that occurred between the examiner and the patentee during the prosecution of the patent to elucidate the construction the patentee intended to disavow. Thus, the majority's new rule, invoking a complete estoppel with no flexibility for a narrowing amendment made for a statutory purpose, effectively disregards the "reason" for a change, in contravention of Warner-Jenkinson.

#### Public Policy

The majority contends that the disclaimer effect, the notice function, and the need for certainty in patent law are supporting public policies for its new strict rule regarding amended limitations. See maj. op. at 24. The majority asserts that by amending a claim for any reason related to a statutory requirement for obtaining a patent, the patentee disclaims subject matter encompassed by the original claim. In view of this disclaimer, the majority contends that it must be strictly construed against the inventor in favor of the public, otherwise the benefit of the doubt as to what was disclaimed comes at the public's expense. See id. at 24-25. But the same arguments

---

<sup>16</sup> This conclusion is further buttressed by the fact that in thinking about prosecution history estoppel, the Court in Warner-Jenkinson had in mind the doctrine as set forth in Bayer Aktiengesellschaft v. Duphar Int'l Research B.V., 738 F.2d 1237, 222 USPQ 649 (Fed. Cir. 1984). See id. at 30 (citing Bayer as a case that sets forth the "well-established limit on non-literal infringement, known variously as 'prosecution history estoppel' and 'file wrapper estoppel.'"). In Bayer, our court stated: "whenever the doctrine of file history estoppel is invoked, a close examination must be made as to, not only what was surrendered, but also the reason for such a surrender. The fact that claims were narrowed does not always mean that the doctrine of file history estoppel completely prohibits a patentee from recapturing some of what was originally claimed." Bayer, 738 F.2d at 1238, 222 USPQ at 653.

can be made for originally filed claim limitations, which, like amended claim limitations, are a disclaimer of certain subject matter.

As mentioned previously, 35 U.S.C. § 112, second paragraph, requires that the patentee specifically claim the invention covered by the patent. The purpose of this statutory requirement to notify the public of the scope of conduct forbidden by the patent is applicable whether a limitation is originally presented by the applicant or added by amendment for any reason related to one of the statutory requirements for obtaining a patent. The majority does not explain why a new bright line rule is compelled to strictly construe the inventor's choice of words in amendments but is not similarly compelled for original claim limitations. Certainly, the benefit of the doubt as to what was disclaimed comes at the public's expense in either case.

Paradoxically, the scope and meaning of claim limitations may be more easily discerned for amended limitations, as compared with originally drafted claim limitations, based on the record developed during prosecution. First-action allowances, with no real interchange or substantive commentary between the applicant and the examiner regarding any of the originally drafted claim limitations, provide no notice of the scope and meaning of those limitations beyond the words themselves as used in the written description and claims. Thus, in some ways, the public-notice function may be better served by explained amended language than by unexplained original claim language, yet the majority's new rule favors the latter by leaving the doctrine of equivalents unrestrained for claim limitations that are not amended.

As the Supreme Court noted in Warner-Jenkinson, "the lengthy history of the doctrine of equivalents strongly supports adherence to [the] refusal [by the Court] in

[Graver Tank] to find that the Patent Act conflicts with that doctrine. Congress can legislate the doctrine of equivalents out of existence any time it chooses.” Warner-Jenkinson, 520 U.S. at 28. The Court specifically noted that the policy arguments that justify keeping or eliminating the doctrine are best addressed by Congress, not the Court. See id. Since the issuance of the Supreme Court’s opinion in Warner-Jenkinson, Congress has not chosen to eliminate the doctrine of equivalents partially or entirely, and I do not believe it is the province of this court to partially legislate out of existence that doctrine for amended claim limitations; particularly in the absence of a compelling justification for treating amended claim language differently than original claim language.

#### Promoting Free Riders v. Promoting Progress of the Useful Arts

The majority contends that the certainty provided by the complete bar approach to amended limitations “will stimulate investment in improvements and design-arounds because the risk of infringement will be easier to determine.” Maj. op. at 28. However, in my opinion, limiting the patentee to protection of only the literal language of an amended claim limitation is not likely to promote the progress of the useful arts. Rather, the majority’s new bright line rule, by constraining limitations amended for a statutory purpose to their literal terms, is likely to encourage insubstantial changes to an established product, rather than investment in break-through technological advancements. Such a rule, therefore, promotes free riding and undercuts the return on a patentee’s investment.

In other words, the majority’s new rule hands the unscrupulous copyist a free ride on potentially valuable patented technology, as long as the copyist merely follows the prosecution history road map and makes a change, no matter how trivial or

insubstantial, to an element otherwise covered by such a narrowed claim limitation. Every other detail of the patented invention may be imitated with impunity. Such an “unscrupulous copyist” appropriates the substance of the invention while avoiding the letter of the claims, yet adds nothing to the technology. The copyist, transformed as a lawful competitor, can take refuge in the excuse that if the patentee wanted better coverage, the claims should have been prosecuted more competently.

As our predecessor court aptly stated: “[t]o allow literalism to satisfy the test for infringement would force the patent law to reward literary skill and not mechanical creativity.” Autogiro Co. of Am. v. United States, 384 F.2d 391, 399 (Ct. Cl. 1967). I do not think that is how our patent system or any patent system was intended to work. Patent laws seek to benefit the inventor's genius, not the scrivener's talents. See id. The majority's new rule, which sanctions the behavior of the copyist who avoids the letter of the claims and adds nothing to the technology, is likely to be a disincentive for inventors to bear the commercial risk in developing and disclosing new technology.

The majority's concern regarding certainty is that under our previous precedent the scope of the estoppel had a spectrum of coverage and there was no precise metric to determine the exact range of equivalents within that spectrum. See maj. op. at 27. This concern regarding the public's ability to know what is and what is not within the confines of a patent monopoly is not a new one.

The dissents in Winans v. Denmead<sup>17</sup>, 56 U.S. (15 How.) 330 (1853), and Graver Tank<sup>18</sup> strongly disagreed with their respective majority's liberal view towards infringement by equivalence, feeling that to interpret the language of the patent to include equivalents would undermine the claiming system and destroy the public's ability to rely on the patent claiming system to mark the boundaries granted to the patentee. See Craane, supra, at 134-35. However, it is noteworthy that the forebodings expressed in the Winans and Graver Tank dissents regarding the impediment to economic growth have not been realized. Competition still abounds in the marketplace and technology has progressed at a remarkable rate.

#### Subject Matter Surrendered

Our prior precedent instructs that “amendments may be of different types and may serve different functions. Depending on the nature and purpose of an

---

<sup>17</sup> “The patentee is obliged, by law, to . . . particularly ‘specify and point’ out what he claims as his invention. Fullness [sic], clearness, exactness, preciseness, and particularity, in the description of the invention, its principle, and of the matter claimed to be invented, will alone fulfill [sic] the demands of Congress or the wants of the country. Nothing, in the administration of this law, will be more mischievous, more productive of oppressive and costly litigation, of exorbitant and unjust pretensions and vexatious [sic] demands, more injurious to labor, than a relaxation of these wise and salutary requisitions of the act of Congress.” Winans, 56 U.S. at 347 (Campbell, J., dissenting).

<sup>18</sup> “The Court's ruling today sets the stage for more patent ‘fraud’ and ‘piracy’ against business than could be expected from faithful observance of the congressionally enacted plan to protect business against judicial expansion of precise patent claims. Hereafter a manufacturer cannot rely on what the language of a patent claims. He must be able, at the peril of heavy infringement damages, to forecast how far a court relatively unversed in a particular technological field will expand the claim's language after considering the testimony of technical experts in that field. To burden business enterprise on the assumption that men possess such a prescience bodes ill for the kind of competitive economy that is our professed goal.” Graver Tank, 204 U.S. at 617 (Black, J., dissenting).

amendment, it may have a limiting effect within a spectrum ranging from great to small to zero. The effect may or may not be fatal to application of a range of equivalents broad enough to encompass a particular accused product. It is not fatal to application of the doctrine itself.” Hughes, 717 F.2d at 1363. For at least the past seventeen years, beginning with our seminal case in Hughes, we have consistently held that prosecution history estoppel bars infringement by equivalents by reason of the patentee’s manifest intent to disavow or abandon a construction of the patent claim as a condition of the patent grant. See Bayer, 738 F.2d at 1243, 222 USPQ at 653; Loctite, 781 F.2d at 871, 228 USPQ at 96; Sun Studs, Inc. v. ATA Equip. Leasing, Inc., 872 F.2d 978, 987, 10 USPQ2d 1338, 1345 (Fed. Cir. 1989); Mark I Mktg. Corp. v. R.R. Donnelly & Sons Co., 66 F.3d 285, 291, 36 USPQ2d 1095, 1100 (Fed. Cir. 1995); Sextant Avionique, S.A. v. Analog Devices, 172 F.3d 817, 830-32, 49 USPQ2d 1865, 1870-72 (Fed. Cir. 1999). Moreover, we have instructed that the intended construction that has been disavowed is to be determined from an objective evaluation of the exchange between the examiner and the patentee that occurred in the prosecution history, whether explicit or implicit.

I agree that the extent to which the patentee would be deprived of equivalents according to our past precedent necessarily involves the often arduous task of reviewing difficult and complex prosecution histories, as well as difficult and complex technologies. I also agree that these difficulties may give rise to differing opinions as to what subject matter is within the scope of the claim and what has been surrendered. However, the mere fact that this court’s new rule is a brighter line for determining whether a patentee is estopped from asserting infringement by equivalents, cannot be

justification for adopting a rule that so substantially changes the rules of the game and discounts the intrinsic worth in treating more fairly the individual inventor whose patent right is under administrative scrutiny and is subject to the inherent limitations of language. The Supreme Court in Warner-Jenkinson saw no “substantial cause for requiring a more rigid rule invoking an estoppel [as a complete bar with no flexibility] regardless of the reason for a change.” Warner-Jenkinson, 520 U.S. at 32. Likewise, I find that the majority’s opinion lacks substantial cause for its rigid rule.

The majority contends that the approach followed by our court in Kinzenbaw v. Deere & Co., 741 F.2d 383, 222 USPQ 929 (Fed. Cir. 1984), is different than the flexible bar approach espoused in Hughes and its progeny. I disagree. In Kinzenbaw our court examined the prosecution record and noted that whether or not the patentee needed to specify the radius of the gauge wheel to overcome the rejection of the claims over specified prior art, he did in fact do just that. Kinzenbaw, 741 F.2d at 388, 222 USPQ at 932-33. After our analysis of the prosecution record, the court also noted that a reasonable competitor would believe that the patentee had surrendered the relevant subject matter in view of the file which “explicitly showed that in response to the examiner’s rejection, [the inventor] narrowed his claims to a planter in which ‘the radius of the wheel . . . [is] less than the radius of the disc.’” Id. In other words, this court’s position was that when the prosecution record is viewed objectively, the patentee manifested an intention to disavow anything but the relationship of the radius of the gauge wheel to the radius of the discs to obtain his patent from the Patent Office, even though it might not have been necessary.

The foregoing does not evince a split in our precedent, but rather comports with Hughes that courts must undertake an examination of the prosecution record to determine the subject matter the patentee disavowed by amendment, whether or not the patentee contends the amendment was necessary to obtaining the patent. As this court has stated: “[u]nmistakable assertions made by the applicant to the . . . PTO . . . in support of patentability, whether or not required to secure allowance of the claim, . . . may operate to preclude the patentee from asserting equivalency . . . .” Texas Instruments Inc. v. United States Int’l Trade Comm’n, 988 F.2d 1165, 1174, 26 USPQ2d 1018, 1025 (Fed. Cir. 1993). The patentee’s subjective determination of whether or not an amendment would have been needed to secure allowance of a claim is irrelevant. If an unmistakable assertion was made by the applicant to the Patent Office to obtain allowance of the patent, as viewed from the objective standpoint of a reasonable competitor, then the scope of prosecution history estoppel is zero. Kinzenbaw is a case that emphasizes that a patentee cannot take one position before the Patent Office to get his claim allowed, whether that position was necessary or not, and then assert a different position in court to prove infringement.

As explained above, I believe it is fair to conclude that the Supreme Court in Warner-Jenkinson left intact the principle of determining that which the patentee surrendered by looking at the exchange between the examiner and the patentee recorded in the prosecution history. Some amendments may be made for a statutory reason, such as providing proper antecedent basis, which is required by 35 U.S.C. § 112, second paragraph’s requirement that the applicant particularly point out and distinctly claim that which is regarded as the invention. However, while such an

amendment affects issuance of the patent, it is a trivial matter. Restricting such an amended claim limitation to its literal scope would unfairly penalize patent owners beyond what is necessary to provide notice and certainty to competitors. As long as the reason for an amendment is explained, and a competitor can reasonably determine what subject matter the applicant surrendered, prosecution history estoppel should preclude the patent holder from recapturing only the surrendered subject matter, not from accessing the doctrine of equivalents entirely. In my view, the flexible approach best balances fairness to inventors with certainty to competitors and strikes an appropriate accord between the required rewards for the already expensive and lengthy process of innovation, and the extra public costs of monopoly profits. See Otterstedt, supra, at 424.

#### CONCLUSION

Because claims are commonly amended during prosecution, prosecution history estoppel touches almost every doctrine of equivalents infringement analysis. See Loctite, 781 F.2d at 871, 228 USPQ at 96. Although a complete bar would provide bright line enhancement of the notice function of claims, it unfairly subjects almost every patentee to the mercy of verbalism at an early stage of development. See Graver Tank, 339 U.S. at 607. Rather than promote technological growth, the majority's new rigid rule will effect a serious invasion of the patentee's security of receiving the full benefit of his invention and is likely to be a disincentive to early disclosure of new inventions and discoveries. I see no substantial cause for the majority's drastic action, and I must, respectfully, dissent from the pronouncement that any time a claim limitation is narrowed by amendment for any statutory purpose, regardless of the nature

and extent of the change, prosecution history estoppel completely bars the application of the doctrine of equivalents.

# United States Court of Appeals for the Federal Circuit

95-1066

FESTO CORPORATION,

Plaintiff-Appellee,

v.

SHOKETSU KINZOKU KOGYO KABUSHIKI, LTD.,  
a/k/a SMC CORPORATION, and SMC PNEUMATICS, INC.,

Defendants-Appellants.

NEWMAN, Circuit Judge, concurring in part, dissenting in part.

This appeal returns to the Federal Circuit on GVR from the Supreme Court,<sup>19</sup> with instructions to reconsider our prior decision in accordance with the law announced in Warner-Jenkinson Co. v. Hilton Davis Chemical Co., 520 U.S. 17, 41 USPQ2d 1865 (1997). Two major issues are presented for our review on remand: (1) application of the Court's new rebuttable presumption and any ensuing estoppel to the claims of Festo's Carroll and Stoll patents; and (2) application of the all-elements rule to the sealing rings of the Carroll and Stoll patents and the magnetizable sleeve of the Stoll patent.

For the first remand issue, today's majority opinion departs from the holdings of Warner-Jenkinson in three important ways. First, the majority holds that all equivalency is barred as to any claim element that is narrowed or added for reasons relating to patentability; access to the doctrine of equivalents is barred whether or not the Court's new rebuttable presumption arises and whether or not it is rebutted. Second, the majority denies consideration to any rebuttal evidence that is not already in the prosecution record, thereby converting the rebuttable presumption into an irrebuttable fiat. Third, the majority's inappropriately broad definition of "reasons related to patentability" further limits a patentee's access to equivalency, and exacerbates the conflict with the holdings of Warner-Jenkinson. The result is to negate infringement by equivalents, as a matter of law, thereby providing a blueprint for ready imitation of

---

<sup>19</sup> Shoketsu Kinzoku K. K., Ltd. v. Festo Corp., 520 U.S. 1111 (1997). The sequence of events called "GVR" (grant, vacate, and remand) occurs when "intervening developments . . . reveal a reasonable probability that the decision below rests on a premise that the lower court would reject if given the opportunity for further consideration." Lawrence v. Chater, 516 U.S. 163, 167 (1996). It is a mandate to the lower courts to apply the intervening developments to the case on appeal, "to ensure the fairness and accuracy of judicial outcomes." Id.

patented products.

The majority does not reach the second remand issue, the application of the all-elements rule. However, the all-elements rule is central to the Supreme Court's treatment of the tension between the doctrine of equivalents and the "notice function" of patent claims. Although my colleagues in the majority identify the "notice function" as the reason for their new and extreme restraints on the doctrine of equivalents, the majority opinion neither discusses nor acknowledges the Court's considered actions to reinforce the notice function.

Thus the majority ignores the bases of the GVR which returned this case to us, and instead manipulates the issues of equivalency and estoppel to achieve a policy-driven result. In acting to severely limit the doctrine of equivalents, this court has made a deliberate change in the relationship between innovator and competitor. Although the Supreme Court rejected judicial entry into this policy arena, the majority has entered headlong, criticizing 150 years of Supreme Court precedent and 18 years of Federal Circuit precedent as "unworkable." This spontaneous judicial action represents a venture into industrial policy whose consequences have been inadequately considered. The majority's announced purpose of facilitating competition by restricting patentees' access to the doctrine of equivalents has not been evaluated for its effect on the nation's technology-based industry, for its effect on the system of patents as an innovation incentive, or indeed for its effect on competition. The interdependent policy aspects of technologic innovation, industrial growth, and competition were not briefed, and do not inhere in this court's "special expertise" in adjudication of patent disputes.

## CONFLICTS WITH THE LAW OF *WARNER-JENKINSON*

### ***Prosecution History Estoppel***

The Court in Warner-Jenkinson confirmed its precedent that estoppel flows from a patent applicant's disclaimer or surrender of subject matter for reasons of patentability; precedent has never held that no equivalency whatsoever is available to amended claim elements. The majority's departures from this law are summarized in its rulings that "an amendment that narrows the scope of a claim for any reason related to the statutory requirements for a patent will give rise to prosecution history estoppel with respect to the amended claim element," maj. op. at 3, that "no range of equivalents is available for the amended claim element," id., and that amendments made to comply with virtually any provision of the Patent Act will raise this estoppel, id. at 9-11. These rulings contravene the Court's holdings in Warner-Jenkinson.

In Warner-Jenkinson the Court summarily dismissed the argument that "any surrender of subject matter during patent prosecution, regardless of the reason for such surrender, precludes recapturing any part of that subject matter, even if it is equivalent to the matter expressly claimed." Warner-Jenkinson, 520 U.S. at 30, 41 USPQ2d at 1871. The Court held that the patentee Hilton Davis, upon establishing the reason why the applicant amended the claims to include a lower pH limit of "approximately 6.0," may be entitled to prove equivalency between a pH of 5.0 and approximately 6.0 in the process of that invention. Observing that it was unclear why the pH limit of 6.0 had been added to the claims, the Court ruled that inclusion of this limitation did not necessarily preclude a finding of infringement based on equivalency:

[W]hile a lower limit of 6.0, by its mere inclusion, became a material element of the claim, that did not necessarily preclude the application of

the doctrine of equivalents as to that element.

Id. at 32, 41 USPQ2d at 1872. The majority's new rules would bar the inquiry for which the Court remanded Warner-Jenkinson to the Federal Circuit.

The Court in Warner-Jenkinson reaffirmed its precedent wherein the patentee is estopped from reaching, through equivalency, subject matter that the applicant had disclaimed or surrendered in order to obtain the patent. See, e.g., Exhibit Supply Co. v. Ace Patents Corp., 315 U.S. 126, 136-137 (1942) (the patentee had "surrendered by amendment," "proclaimed his abandonment of" and "disclaimed" the subject matter that was used by the accused infringer); Smith v. Magic City Kennel Club, Inc., 282 U.S. 784, 790 (1931) (describing an amendment made after persistent examiner's rejection as a "disclaimer"); Weber Electric Co. v. Freeman Electric Co., 256 U.S. 668, 676 (1921) ("it is clear that the chief concern of the applicant [after rejection] was to distinguish his construction from that of Kenny, which is very similar to [that of the accused infringer]"). These cases, although mentioned in the majority opinion, do not support the majority's new rules, for in no case did the Court find an estoppel as to subject matter that was not surrendered in order to obtain the patent and that was not embraced in the difference between the prior art and the applicant's invention.

The majority recasts prosecution history estoppel in a legally incorrect and equitably unjust manner. As illustrated by the Carroll and Stoll patents in suit, equivalents are now held forfeited whether or not the claimed element itself was amended, or even discussed, during prosecution. In contrast, the Court has consistently held that the law of estoppel requires determination of what was surrendered and why, measured by the representations made by the applicant in order

to obtain the patent. Precedent as to prosecution history estoppel is strikingly uniform in not only the judicial statement of the law, but in its application. There has been no groundswell of concern for unpredictable judicial application of the rules of estoppel, even by those who have expressed concern for unpredictable application by juries of the rules of equivalency. Today's actions imposing an absolute estoppel against equivalency - instead of sharpening the criteria for determining equivalency (as the Court instructed) - make manifest the magnitude of the majority's change in the law.

### ***The Rebuttable Presumption***

As part of its reinforcement of the notice function of claims, the Court established a new rebuttable presumption. In accordance with this presumption, when the prosecution record is silent as to the reason for a change to the claims, the presumption arises that the change was made for "a substantial reason related to patentability." Warner-Jenkinson, 520 U.S. at 33, 41 USPQ2d at 1873. This new presumption and ensuing estoppel are carefully designed controls that require consideration of the "reasoning behind the Patent Office's insistence upon a change in the claims." Id. at 32, 41 USPQ2d at 1872. The Court recognized that estoppel does not arise from every change, but depends on whether the change was made for patentability reasons:

Where the reason for the change was not related to avoiding the prior art, the change may introduce a new element, but it does not necessarily preclude infringement by equivalents of that element.

Id. The patentee may then come forward with evidence to rebut the presumption. Id. at 33, 41 USPQ2d at 1873.

The majority holds that the presumption can only be rebutted by evidence that is already present in the prosecution record. Maj. op. at 48 ("a patent holder seeking to establish the reason for an amendment must base his arguments solely upon the public record of the patent's prosecution, i.e., the patent's prosecution history"). Thus the majority holds that the rebuttable presumption concerning the reason for an amendment, which presumption arises when the prosecution record is silent as to the reason for the amendment, can not be rebutted with evidence outside of the prosecution record. The rebuttable presumption thereby becomes irrebuttable, because the prosecution record is necessarily silent in order for the presumption to

arise at all. This impossibility of rebuttal was surely not contemplated by the Court in creating "[t]he presumption we have described, one subject to rebuttal if an appropriate reason for a required amendment is established . . . ." Warner-Jenkinson, 520 U.S. at 33, 41 USPQ2d at 1873.

The nature of a presumption is that it is not sacrosanct on the grounds on which it arose, but can be countered by evidence. See Fed. R. Evid. 301 ("a presumption imposes on the party against whom it is directed the burden of going forward with evidence to rebut or meet the presumption"). A presumption is a procedural expedient whereby a conclusion of law or ultimate fact is deemed established upon the proof of certain evidentiary or historical facts. An opposing party may rebut the presumption by coming forward with evidence sufficient to negate the conclusion or its factual premises. See generally 21 Charles Alan Wright & Arthur R. Miller, Federal Practice and Procedure §5124 (3d ed. 1998). The majority's ruling confuses the grounds on which a presumption arises with the grounds on which it is subject to rebuttal. The role of the prosecution record is to establish whether the presumption arises at all, not whether it has been rebutted.

That the majority's ruling makes rebuttal impossible is illustrated by the patents in suit. Since Festo's explanation of its amendment to the Carroll claims is now limited to the prosecution record, the presumption can not be rebutted because the prosecution record is silent as to the reason for the amendment. Indeed, since there is no requirement that a patent applicant explain amendments made before an examiner's rejection on the merits - the situation for both the Carroll and Stoll patents - evidence explaining such amendments is not normally present in the prosecution record.

The Supreme Court was explicit that "The presumption we have described [is] subject to rebuttal . . . ." 520 U.S. at 33, 41 USPQ2d at 1873. The majority's denial of rebuttal evidence outside the prosecution record is equally explicit, with the consequence that the subject matter of unexplained amendments can receive "no range of equivalents." Maj. op. at 13. The error in this implementation is made clear in the Warner-Jenkinson case itself. In Warner-Jenkinson the Court observed that "the record seems not to reveal the reason" for the amendment setting the lower pH limit, that the patentee has the burden of establishing the reason, and that "respondent has not proffered in this Court a reason for the addition of a lower pH limit." The Court therefore remanded to the Federal Circuit for determination of whether the patentee could establish a reason for this amendment. Under the regime established by the majority opinion, the Court's remand would be pointless. The Court similarly remanded the Festo case now before us. Our obligation is to implement the remand in accordance with its terms, and to determine whether Festo can rebut the presumption that the claims were changed for a reason related to patentability.

### ***"Reasons Related to Patentability"***

In Warner-Jenkinson the Court explained that amendments made for "a substantial reason related to patentability" means amendments made to establish patentability in view of substantive rejections. The Court observed that there are "a variety of other reasons why the PTO may request a change in claim language" without producing an estoppel, 520 U.S. at 31, 41 USPQ2d at 1872, citing the *amicus curiae* brief of the United States. The United States had pointed out that amendments "to reflect the scope of what was enabled or to add specificity raise considerations different

from those raised by amendments to avoid prior art." Brief for United States as *Amicus Curiae* at 22-23, 1996 WL 172221, \*22-\*23. The Court endorsed this understanding of estoppel, explaining:

Our prior cases have consistently applied prosecution history estoppel only where claims have been amended for a limited set of reasons, and we see no substantial cause for requiring a more rigid rule invoking an estoppel regardless of the reasons for a change.

520 U.S. at 32, 41 USPQ2d at 1872.

The Court's emphasis on a "limited set of reasons" is in striking contrast to the unconstrained estoppel established by the majority for any change made in connection with any provision of the Patent Act. In Warner-Jenkinson the Court unequivocally rejected this position, stating that the petitioner "reaches too far in arguing that the reason for an amendment during patent prosecution is irrelevant to any subsequent estoppel." 520 U.S. at 30, 41 USPQ2d at 1867. The Court stated: "That petitioner's rule might provide a brighter line for determining whether a patentee is estopped under certain circumstances is not a sufficient reason for adopting such a rule." Id. at 32 n.6, 41 USPQ2d at 1872 n.6. The majority now adopts this rejected position.

Supreme Court and Federal Circuit precedent have well recognized that prosecution history estoppel flows from amendments on substantive grounds of patentability. The principal statutory provisions involved during examination for patentability are 35 U.S.C. §102 and §103; parts of §112 may also give rise to estoppel. However, not every rejection based on the Patent Act is concerned with substantive grounds of patentability, as the Court also recognized. An illustration is the Stoll claims, which were rejected not on prior art but as being in improper multiple dependent form, another provision of §112; Stoll's claims amended in response to this ground of

rejection are today held barred from access to the doctrine of equivalents.

The majority discards as "unworkable," maj. op. at 27, the vast body of precedent which holds that determination of the extent of estoppel requires consideration of the reason for the amendment. See, e.g., Bayer Aktiengesellschaft v. Duphar Int'l Research B.V., 738 F.2d 1237, 222 USPQ 649 (1984) (cited in Warner-Jenkinson) ("Whenever the doctrine of file history estoppel is invoked, a close examination must be made as to, not only what was surrendered, but also the reason for such a surrender.") Instead, the majority adopts the brighter line that the Court rejected. Thus although I concur with the majority's answer to Question 1 in that precedent holds that estoppel may arise on substantive grounds of patentability in addition to those of §102 and §103, I do not share the majority's application of this answer to include any amendment responding to a rejection under any provision of the Patent Act.

### ***Federal Circuit Precedent***

The majority seeks to buttress its departure from the law of Warner-Jenkinson by stating that it is simply resolving "conflicting lines" of Federal Circuit precedent. However, that is neither an accurate description of our precedent, nor an adequate reason to discard it.

Federal Circuit decisions applying the doctrine of equivalents have turned not on "conflicting lines" of precedent, but on the facts of each case. This precedent illustrates the variety of situations that can arise as to the technologic facts of asserted equivalency, as well as the variety of circumstances of estoppel. At one factual pole are cases that illustrate a patentee's disclaimer, during prosecution, of precisely what

the accused infringer is doing. Such cases tend to inspire righteous judicial rhetoric against over-reaching patentees; these opinions voice what the majority terms a "strict" approach to the doctrine of equivalents. At the other factual pole are cases that the majority classifies as the "flexible" approach, the majority's disapproving term for those decisions where liability based on equivalency was found.

This jurisprudence reflects not two disparate lines of conflicting authority, but rulings of estoppel and findings of equivalency *vel non* in a continuum of situations, from those that clearly warranted liability to those that clearly did not. It is inappropriate to convert the extremes of this continuum into "conflicting lines," and then to use this contrived conflict to justify changing the law to eliminate not only both lines but also everything in-between.

The principal case cited for the majority's "strict line" is Kinzenbaw v. Deere & Co., 741 F.2d 383, 222 USPQ 929 (Fed. Cir. 1984). In Kinzenbaw the accused device "adopted the very element that [the patentee] had eliminated for the stated purpose of avoiding the examiner's rejection and obtaining the patent." Id. at 389, 222 USPQ at 933. Holding that the patentee was estopped from asserting equivalency, the Federal Circuit stated that it would not undertake to decide whether Kinzenbaw gave up more than he had to in order to obtain allowance. Kinzenbaw has not heretofore been viewed as producing an irreconcilable conflict in precedent. As it was contemporaneously explained, Kinzenbaw "highlight[s] that application of prosecution history estoppel to limit the doctrine of equivalents should be performed as a legal matter on a case-by-case basis, guided by equitable and public policy principles underlying the doctrines involved and by the facts of the particular case." Loctite Corp.

v. Ultraseal Ltd., 781 F.2d 861, 871 n.7, 228 USPQ 90, 96 n.7 (Fed. Cir. 1985).

The majority flags Hughes Aircraft Co. v. United States, 717 F.2d 1351, 219 USPQ 473 (Fed. Cir. 1983), as the pole of the disapproved "flexible line." In Hughes Aircraft this court reiterated the rule that a patentee is estopped to recover through equivalency the scope that was disclaimed for reasons of patentability. Id. at 1362, 219 USPQ at 481. The ruling of equivalency on the facts of Hughes Aircraft, an issue of later-developed technology, has repeatedly been sustained. See Hughes Aircraft v. United States, 140 F.3d 1470, 46 USPQ2d 1285 (Fed. Cir. 1998) (redetermination of equivalency upon the GVR, 520 U.S. 1111, based on Warner-Jenkinson).

Although the questions presented in precedent were often close, and not every judge was always of identical view, not even the "strict line" attributed to Kinzenbaw represents the extreme position now adopted. In Warner-Jenkinson the Court rejected the position that any surrender of subject matter establishes "bright lines beyond which no equivalents may be claimed." 520 U.S. at 30, 41 USPQ2d at 1871. The law of Warner-Jenkinson bars the position now taken.

### ***The "Notice Function" of Claims***

The Supreme Court, reviewing its precedent on equivalency since Winans v. Denmead, 56 U.S. (15 How.) 330 (1854), recognized the long-standing tension between equivalency and the "notice function" of patent claims. The Court acted to reinforce the "notice function" by imposing a new combination of criteria for equivalency, comprising (1) the new rebuttable presumption for unexplained amendments, (2) the all-elements rule, and (3) the obligation to examine "the role played by each element in the context of the specific patent claim." Warner-Jenkinson,

520 U.S. at 40, 41 USPQ2d at 1875.

Discussing the rebuttable presumption, the Court stated that "The presumption we have described . . . gives proper deference to the role of claims in defining an invention and providing public notice . . . ." Id. at 33-34, 41 USPQ2d at 1873. The Court also explained that the all-elements rule secures the "central functions of the patent claims themselves," id. at 30, 41 USPQ2d at 1871, while prosecution history estoppel, reinforced by the new rebuttable presumption, "further insulates the doctrine from any feared conflict with the Patent Act." Id. at 34, 41 USPQ2d at 1873. The Court also mentioned factors such as known interchangeability and other criteria relevant to the determination of equivalency.

The notice function of claims was thereby enhanced, for there can be no liability for infringement, even by a clear technologic equivalent, unless every claimed element of the patented device is appropriated and used, in the same role as in the claim, without encountering estoppel. A device that does not meet all of these legal and factual criteria does not incur liability despite technologic equivalency. However, a device that is unable to omit or substantially change even one claimed element, and that is not released by the prosecution history, has notice of probable liability for infringement.

Thus the Court acted to preserve the purpose of the doctrine of equivalents to prevent "fraud on the patent," while taking specific steps to reinforce the notice function of patent claims. The majority opinion remains silent on this important action to sharpen application of the doctrine of equivalents while preserving the principle of its availability. Instead, the majority relies on its "experience" as justification for its

changes of law, but makes no mention of the Court's careful balance of controls, or explain why it is inadequate. See maj. op. at 26 ("Our decision to reject the flexible bar approach adopted in Hughes I comes after nearly twenty years of experience in performing our role as the sole court of appeals for patent matters.") We should use that experience to refine the criteria of equivalency, as the Court expected, instead of eliminating it entirely, a ruling that bars remedy to the deserving and undeserving alike.

In the complex of risk-laden concerns and uncertainties involving inventions, entrepreneurship, and competition, the doctrine of equivalents weighs on the side of the patentee, for it provides the possibility of protection against close copies which merely skirt the patent's claims. In this way it adds weight to the patent system as an innovation incentive. The majority of this court apparently views the existing balance between inventor and imitator as disadvantageous to the nation, for the court now sets as "paramount" the "notice function" to the would-be competitor. However, the optimum balance between innovator and imitator in a technology-dependent economy involves many considerations in addition to the primacy of notice.

## II

### THE PATENTS IN SUIT

Applying the pre-Warner-Jenkinson law of equivalency, the district court adjudged both the Carroll and Stoll patents to be infringed, the Carroll patent on summary judgment and the Stoll patent by jury verdict. On the prior law, and again on the law of Warner-Jenkinson, those judgments were twice affirmed on appeal. Today the merits are not reached, simply because the claims of both patents were rewritten in narrower form before they were examined. For the Carroll patent, Festo added an

element to the claims before reexamination. For the Stoll patent, Festo rewrote improper multiple dependent claims, dropping the broader claim. In neither the Carroll nor the Stoll patent were the elements at issue amended; however, in both patents estoppel is now held to be complete, barring any assertion of equivalency as to these elements.

### ***The Carroll Patent***

Festo requested reexamination of the Carroll patent in light of German Patent No. 1,982,379, which had not been included in the original examination. After the reexamination request was granted but before reexamination on the merits, Festo cancelled original claim 1 and added a new claim which differed from the original claim in several ways including the addition of "a pair of resilient sealing rings." Festo did not explain these changes; nor was explanation required, for the changes were made before action by the examiner.

The majority holds that the presumption arises that the sealing rings were added to the claim for reasons of patentability, for the prosecution record does not state why this amendment was made. However, the majority limits the rebuttal evidence to the prosecution record that produced the presumption. See maj. op. at 49 ("We therefore hold that a narrowing amendment will give rise to prosecution history estoppel unless the prosecution history of the patent reveals that the amendment was made for a purpose unrelated to patentability concerns.") Since the prosecution history is silent as to the reason for the amendment, Festo is held unable to rebut the presumption.

Festo points out on this appeal that sealing rings were described in the cited German patent, and thus that this element did not impart a distinction from the prior art.

Festo's argument during reexamination related to other components of the device:

[The cited references] do not disclose the overall structure of the device for moving articles set forth in the claim, and in particular do not disclose 1) a plurality of cylindrically-shaped permanent magnets mounted on a central mounting member and spaced axially apart from each other . . . 2) an exterior body including a plurality of annularly shaped permanent magnets spaced apart from each other and 3) a pair of cushion members formed of resilient material . . . . [Emphases in original]

The examiner mentioned several components of the combination in the "Reasons for Allowance," but not the sealing rings:

Claims 3, 4, 5, 6, and 9 are deemed allowable over the prior art of record, including German Patent No. 1,982,379 because the prior art does not teach or render obvious the claimed combination which includes the plurality of magnets, end members, and cushion members in the claimed relationship.

The sealing rings raise the only issue with respect to infringement under the doctrine of equivalents; all of the other claim elements were conceded to be literally present in the SMC devices.

The sealing rings were not amended during prosecution. No argument by the applicant was directed to the sealing rings, and no issue of patentability concerning the sealing rings was raised by the examiner. Nonetheless, the majority holds that it suffices as a "narrowing amendment" that the claim as a whole was narrowed when the sealing rings were added before examination. Applying the majority's new rule that any narrowing amendment entirely bars access to equivalency, the factual question of equivalency between the claimed pair of sealing rings and the SMC two-way sealing ring is not reached.<sup>20</sup> Thus the majority holds that the addition of the sealing rings to

---

<sup>20</sup> In the district court the issue of equivalency of the sealing rings was based on the all-elements rule, a question that is mooted by the majority's ruling that equivalency can not be asserted at all.

the Carroll claims before examination, without more, immunizes the SMC devices from the charge of infringement under the doctrine of equivalents.

### ***The Stoll Patent***

The Stoll patent application was filed in the United States as the English translation of a prior German patent application. In the first action in the United States, the examiner rejected the application under 35 U.S.C. §112 ¶1, stating: "Exact method of operation unclear. Is device a true motor or magnetic clutch?" The examiner also objected to claims 4-12, which apparently were filed in the same form as in the foreign priority application, as being in improper multiple dependent form, citing 35 U.S.C. §112 ¶2 [sic: ¶5?]. The examiner also listed three references as "believed pertinent"; the references were not discussed and no rejection was made on prior art.

In response, Stoll explained the method of operation and amended the specification accordingly. Stoll also rewrote the claims, eliminating the improper multiple dependent form. Stoll cancelled original claim 1 and filed a new independent claim that included the subject matter of original dependent claims 4 and 8. From claim 4 Stoll took "first sealing rings located axially outside said guide rings," and from claim 8 Stoll took "a cylindrical sleeve made of a magnetizable material and encircles said tube." Thus in the new claim these elements were more narrowly claimed than in original claim 1, although not more narrowly than in original dependent claims 4 and 8. The record states no reason for these changes.

Stoll also submitted two German patents that had been cited during examination of the corresponding German application, with the following explanation:

Applicant wishes to make of record German Offenlegungsschrift No. 27

37 924 and German Gebrauchsmuster No. 19 82 379. These references were cited in the first Office Action received in the corresponding German application. These references are obviously clearly distinguishable over the subject matter of the claims now present in this application. Accordingly, further comment about the subject matter of these references is believed unnecessary. It is clear that neither of these references discloses the use of structure preventing the interference of impurities located inside the tube and on the outside of the tube while the arrangement is moved along the tube.

The majority finds that the above reference to "structure preventing the interference of impurities" relates to the sealing rings; nonetheless, the majority also rules that all access to equivalency is barred because the broadest claim was "narrowed" by amendment, although the scope of the elements as stated in the original dependent claims was not at issue. Disposing of Festo's argument that the prosecution history shows that the claims were rewritten in response to the rejection for improper multiple dependent form, the majority holds that "Because a claim will not issue unless it satisfies the requirements of section 112, an amendment made to satisfy the statute is an amendment made for a reason related to patentability." Maj. op. at 54. Thus this amendment is held to bar access to the doctrine of equivalents because the rejection was based on a statutory formal requirement.

The court does not reach the questions of identity of function, way, and result, or the insubstantiality of the change, or interchangeability in the context of the invention. The formulaic framework of the majority opinion thus vitiates the doctrine of equivalents, without respect to the merits of any particular claim.

### ***The Retroactive Effect***

It has been routine practice for patent solicitors to initially present broad claims to an invention, in the expectation of honing the claims in interaction with the examiner.

As very few patent applications traverse the PTO without amendment or argument,<sup>21</sup> few issued patents will be free of the consequences of these changes in the law, for the majority has declined to act on the warnings against derogation of vested rights and expectancies, and has declined to make this decision applicable only prospectively. See Warner-Jenkinson, 520 U.S. at 41-2, 41 USPQ2d at 1876 (Ginsburg, J., concurring).

In addition, a profound inequity is now created between those patents that may fortuitously have managed to avoid amendment or argument as to all elements subject to imitation by insubstantial change, and those that have not. The practical significance has not been explored in the majority opinion, and indeed this aspect was not briefed or argued.

### III

#### INNOVATION AND COMPETITION POLICY

Although various policy arguments were briefed to the Court in the Warner-Jenkinson appeal, the Court declined to enter the policy arena:

The lengthy history of the doctrine of equivalents strongly supports adherence to our refusal in Graver Tank to find that the Patent Act conflicts with that doctrine. Congress can legislate the doctrine of equivalents out of existence any time it chooses. The various policy arguments now made by both sides are thus best addressed to Congress, not this Court.

520 U.S. at 28, 41 USPQ2d at 1871. The majority disregards this admonition and,

---

<sup>21</sup> Patent examination practice requires the examiner to cite the closest references found in a search of the prior art. See Manual of Patent Examining Procedure '706. The applicant then must respond and explain why the invention is patentable over the references, and may amend, add, cancel, and rewrite claims. MPEP '714.02. Informal inquiry reports that for simple inventions, at most 10-15% of patents are granted without claim amendment, although very rarely without argument.

despite the absence of development of policy issues on this appeal, legislates a new balance between inventor and imitator. The optimum balance is critical to the nation's economy.

The modern industrial economy is driven by technologic innovation. It has long been understood that technological advance and industrial vigor flow from legal and economic policies that encourage invention and support investment in the products of invention. The extensive scholarship in this area is founded on the classical studies of Joseph A. Schumpeter, Capitalism, Socialism and Democracy, Harper, New York (3d ed. 1950) (recognizing the economic impact of patent-based innovation as new industries and new goods displace the old), and has been broadly explored, e.g., Kenneth J. Arrow, Economic Welfare and the Allocation of Resources for Invention (1962) (discussing intellectual property rights in a free enterprise economy); Robert Solow, Technical Change and the Aggregate Production Function, 39 Rev. Econ. & Stat. 312 (1957).

The encouragement of invention and investment in new ideas and their embodiments is a primary function of patent systems, aimed at the national purpose of development of new industries, improved productivity, increased employment, and overall economic growth as well as technologic advance. There is burgeoning modern scholarship directed to studies of invention, investment, and patent systems, generally building on the work of William D. Nordhaus, Invention, Growth, and Welfare: A Theoretical Treatment of Technological Change, M.I.T. Press, Cambridge (1969), and other scholars such as Kenneth M. Dam, The Economic Underpinnings of Patent Law,

---

For complex inventions the percentage of unamended applications is vanishingly small.

23 J. Leg. Studies 247 (1994); David Silverstein, Patents, Science and Innovation: Historical Linkages and Implications for Global Technological Competitiveness, 17 Rutgers Computer & Tech. L.J. 261 (1991); and Friedrich-Karl Beier, The Significance of the Patent System for Technical, Economic and Social Progress, 11 Int'l Rev. Indus. Prop. & Copyright L. 563 (1980). Critical attention has been given to aspects such as the nature of the technology, the rate of technologic change in the particular field, the maturity of the field, the cost of invention and development for various technologies, market risks and competitive structures, the ease and cost of imitation, and the choice between disclosure in patents and maintaining the technology in secrecy. International patenting and trade aspects have been explored, as well as the cost of patenting and the cost of enforcement. E.g., Nancy T. Gallini, Patent Policy and Costly Imitation, 32 RAND J. Econ. 56 (1992) (discussing factors such as licensing policy and technological difficulties); Richard J. Gilbert & David M. G. Newberry, Preemptive Patenting and the Persistence of Monopoly, 72 Am. Econ. Rev. 514, 519, 522 (1982) (industry-specific conditions such as the existence of patentable substitutes and cross-licensing, as well as costs of litigation, affect strategic behavior).

The field of innovation study has evolved to include such complexities as "sequential" innovation, wherein one invention follows from the disclosure of another, e.g., Jerry R. Green and Suzanne Scotchmer, On the Division of Profit in Sequential Innovation, 26 RAND J. Econ. 20 (1995) (pointing out that patent length and breadth play a different role when innovation is sequential); G. M. Grossman and E. Helpman, Quality Ladders in the Theory of Growth, 58 Rev. Econ. Stud. 43 (1991) (discussing how investment in sequential innovation drives economic growth).

It is well recognized that all of these aspects have varying weights, and that the circumstances surrounding the development and utilization of intellectual property are extremely diverse. Indeed, commentators complain that a single patent policy and patent law are unsuited to the range of scientific and commercial activity in today's economy.

Thus scholarship is providing rigor to understanding the role of intellectual property in innovation/competition policy, even as the limitations of economic models of invention, risk, and investment are recognized. Scholars writing in this field tend to introduce their analyses with a salute to complexity and an apology for their simplifications. However, within the growing body of scholarship, studies of the relationship between industrial innovation and optimal patent policy weigh against the majority's policy decision here. A paper entitled Optimal Patent Design and the Diffusion of Innovations, Carmen Matutes, Pierre Regibeau & Katherine Rockett, 27 RAND J. Econ. 60, 78 (1996), concludes that "the optimal scope policy implies that inventors of basic innovations obtain protection on applications that they have not yet fully worked out. This would probably require a more lenient review of claims than is the current practice." Edmund W. Kitch in The Nature and Function of the Patent System, 20 J. L. & Econ. 265 (1977) proposes that optimum patent policy should provide sufficiently broad scope to the inventor who opens a new field, to provide adequate economic incentives while avoiding duplication of effort and discouraging recourse to secrecy. D.G. McFetridge and M. Rafiquzzaman in The Scope and Duration of the Patent Right and the Nature of Research Rivalry, 8 Research in Law & Economics: The Economics of Patents and Copyrights 91, 104 (1986) discuss how the

existence of non-infringing substitutes alters the benefit gained by an inventor, necessarily skewing incentives to invest.

It is generally agreed that long-term economic growth requires a policy framework that encourages the creation and commercialization of new technologies, as contrasted with a policy that facilitates appropriation of the creative product, lest the creative product dry up in the face of too-easy appropriation. "Knowledge capital," secured by intellectual property rights, now rivals the traditional economic components of labor productivity, capital formation, and natural resources, as the foundation of economic growth.

The inventor and the imitator are affected by quite different economic considerations. The innovator takes the risk of commercial success or failure of new things in new markets -- the risk of unfulfilled expectations, obsolescence, regulation, technologic failure. The imitator bears none of these risks; he is interested only in the successful products, not in the failures; he is interested only in the profitable products, not the marginal ones; he moves in only after the invention has been made and tested and the market developed, and can operate at lower margins. The patent system provides weight on the side of the innovator, aided by the doctrine of equivalents and its inhibition of close copying, establishing an incentive whose value has been tested by time. However, it is also well recognized that competition is essential to a healthy economy. Achieving the optimum balance of these factors is of vital national importance. A major policy change in the foundational law affecting innovation and competition should not be made without adequate study of its consequences.

Although there is burgeoning literature on technologic intellectual property rights,

the doctrine of equivalents has not, of itself, been a major focus of legal and economic scholarship. I suspect this is due to the complexity of the issue, the variety of factual applications, the diversity of technologies, the breadth of interacting influences on patentees' and competitors' activities, and the complex nuances of competition at the edge of the products of others. A few authors, however, have critically considered the doctrine of equivalents. For example, Robert P. Merges & Richard R. Nelson, in On the Complex Economics of Claim Scope, 90 Colum. L. Rev. 839 (1990), observe that the doctrine of equivalents tends to diminish incentives for competitors, but point out that the doctrine also encourages competitors to make "leapfrogging" advances instead of simply copying at the edge of the claims. The questions raised by the doctrine of equivalents are not quite the same as those of patent "scope." The issue of "scope" is directed to aspects of literal claim breadth, as discussed by Kitch, supra. The question of equivalency is quite different. Infringement under the doctrine of equivalents is available only against what is indeed the same invention with only insubstantial change, as contrasted with issues of broad claims for broad but undeveloped concepts. Equivalency is a judgemade response to the pernicious literalism of the system of claiming, not an enlargement of the scope of the invention.

My colleagues in the majority make the error of the "simplified model," which assumes a continuing supply of new products, and ignores the prior steps of invention and commercialization. The majority concludes that the elimination of liability for infringement based on equivalency will be of public benefit: "The public will be free to improve on the patented technology and design around it . . . . [C]ertainty will stimulate investment in improvements and design-arounds." Maj. op. at 32. However, the

assumption that placing new technology in the public domain is always the optimum path to industrial growth is not supported by experience. Empirical studies have added rigor to the common sense knowledge that reduced profit opportunity affects the supply of capital to launch a new technology, and often the creation of the technology itself. See, e.g., Joshua Lerner, *The Importance of Patent Scope: an Empirical Analysis*, 25 RAND J. of Econ. 319 (1994) (reviewing 173 venture-backed biotechnology firms and reported that an increase of one standard deviation in average patent scope produced a 21% increase in the firm's value).

The present patent law has supported a blossoming of technology-based industry in a competitive environment that is conspicuous for its entrepreneurial vigor. The balance among inventor, investor, competitor, and consumer, and the effect of the doctrine of equivalents on that balance, is not explored in the parties' briefs and had sparse *amicus* participation, for it was not at issue. Of course no patentee would choose to rely on the doctrine of equivalents to support commercial investment. The public and private interests served by the doctrine of equivalents derive from its deterrence of close imitation, thereby helping to assure to the patentee the benefit of the invention,<sup>22</sup> while obliging would-be competitors to advance the technology instead of simply skirting the edge of the claims. Although its influence is not easy to quantify, it is generally accepted that the doctrine contributes to an industrial policy that seeks to support technologic innovation.

## CONCLUSION

---

<sup>22</sup> The majority exhibits either hubris or humor in explaining that the patentee who is denied access to equivalency is also benefitted because he is spared the cost of enforcing his patent against the equivalent product that has undercut his

The policy underlying the doctrine of equivalents has been sustained by the absence of alternative remedy in meritorious cases, when the patentee's invention has indeed been taken by trivial change from the letter of the claims. By enabling remedy when remedy is warranted, the doctrine adds strength to the system of patents. Today's technological vitality arose on a patent system that included the doctrine of equivalents. A change in the balance between inventor and imitator requires careful understanding of the consequences; a preference for the neatness of precise "notice" does not justify major tinkering with the overall strength of the patent system, with unknown consequences. This court's new recipe for risk-free copying of patented inventions presents policy considerations of national import.

The doctrine of equivalents has not been deemed superfluous as an instrument as justice, and not until today has it been deemed "unworkable" by this court. The Federal Circuit's *sua sponte* change in this law is a change in industrial policy that requires public discussion in advance of, not after, the law has been changed.<sup>23</sup> This court's initiative flows uncomfortably as a ruling that affects myriad vested rights, on a novel legal theory, without briefing or argument.

---

prices and taken his market. Maj. op. at 32.

<sup>23</sup> My colleagues' complaint about the frequency of issues of equivalency in litigation must be viewed in context. Less than a hundred patent cases are fully tried each year, and most of the few hundred appeals to the Federal Circuit reach us on summary disposition. Infringement cases often raise issues of equivalency, usually offered as an alternative theory to literal infringement. These are very small numbers in light of over 1,700,000 unexpired patents, of which 1,200,000 are maintained and in force. Cases in litigation do not provide courts with a balanced picture of the workings of commerce. Litigants rarely explore national policy, as committed parties battle for high stakes. Such cases do not present an objective exposition of the overriding national interest.

